



H Series 60 Gallon Stationary Whirlpool H-60-S



Product photo/image above may show some available options

H-60-S Stationary Whirlpool is recommended for shallow or deep body immersion offering complete coverage of the lower extremities as well as the lower back and hip.

Tank Capacity is 60 gallons.

Whirlpool Tank is 36"L x 20"W x 28"D and is seamless welded construction, fabricated from heavy gauge, type 304 stainless steel, polished to a satin finish. Tank rim is reinforced with a concealed stainless steel rod. Tank bottom is seamless, rounded coved design to minimize bacteria buildup. Tank is also provided with an extended stainless steel skirt flush to the floor line to conceal internal drain piping.

A 2" Combination Drain and Overflow, and a Filler Spout are provided. (See roughing-in dimensions on the reverse side).

Turbine Raising and Lowering Device permits adjustment of desired height and direction of water agitation towards the area of the body to be treated. It is spring balanced and provided with a locking device.

Turbine Assembly functions both as agitator and emptying device. It is equipped with Underwriters Laboratory listed 1/2 HP jet pump motor protected with an ABS plastic shell, and automatic thermal overload protector, and lifetime-sealed bear-

ings. All parts contacting the water are stainless steel, chrome plated brass or bronze.

Thermometer is provided with a dual scale, adjustable calibration, and a stem inserts into a retainer to prevent rattle during whirlpool agitation.

GUIDE SPECIFICATIONS

Provide Stationary Whirlpool (specify model number and options) with a 60-gallon capacity, 36"L x 20"W x 28"D. Whirlpool shall be fabricated from heavy gauge, type 304 stainless steel. Construction shall be seamless welded and exposed surfaces shall be polished to satin finish. Tank shall have a reinforced rim and shall be fitted with a stainless steel skirt flush to the floor line. Bottom of tank shall be a seamless, rounded coved design to minimize bacteria build up. Provide a 2" combination drain and overflow, and a filler spout. Provide a turbine assembly with raising and lowering device which functions both as agitator and emptying device, permits adjustment of desired height, direction of water agitation, and can be locked into place. Turbine assembly shall be UL listed 1/2 HP jet pump motor with automatic thermal overload protector, and lifetime-sealed bearings. Provide a 3" dial thermometer with a stem retainer to prevent rattle when whirlpool is in operation.



Member of
U.S. Green
Building Council



Recycleable
Product

Hi-Boy Whirlpools

MODEL NUMBER AND OPTION SELECTIONS

Series

- H Hi-Boy Series

Capacity

- 60 Gallons

Type

- S Stationary Whirlpool

Suffix Options (See Whirlpool Option Section for Details)

- AHC1 Adjustable High Chair with Casters
- AHC2 Adjustable High Chair with Rubber Tips
- ARS Arm Rest Support
- AS1 Adjustable Suspension Seat
- CTS1 Combination Table with Side Seats
- EG Enviro Glaze Color Powder Coating -

Specify Color: _____

(Special Finish Consult Factory)

- GFI Ground Fault Interrupter
- MXT1 Thermostatic Mixing Valve (15 G.P.M.)
- MXT2 Thermostatic Mixing Valve (25 G.P.M.)
- MXWH Washout Hose Attachment for MXT Valves
- PCS Pump Cover Strainer
- PHS2 Patient Handling System (Chair type)
- RHG Rubber Hand Grips
- SDO Separate Drain and Overflow Assembly
- TTS1 Tank Top Seat

Turbine Assembly

Electrical on standard turbine supplied is 115 V 60 Hz
if 220 V is required please specify:

- 50 Hz
- 60 Hz

All dimension figures in parentheses are in millimeters.

ELECTRIC REQUIREMENTS:
Amps: 8
Volts: 115
Hertz: 60
GFI Receptacle



VALVE	INLETS	OUTLET	DIM A	DIM B	DIM C
MXT1 (15 GPM)	1/2" NPT	1/2" NPT	8-1/2" (215)	13-3/4" (350)	18" (455)
MXT2 (25 GPM)	3/4" NPT	3/4" NPT	9-1/2" (240)	13-1/2" (345)	17" (430)

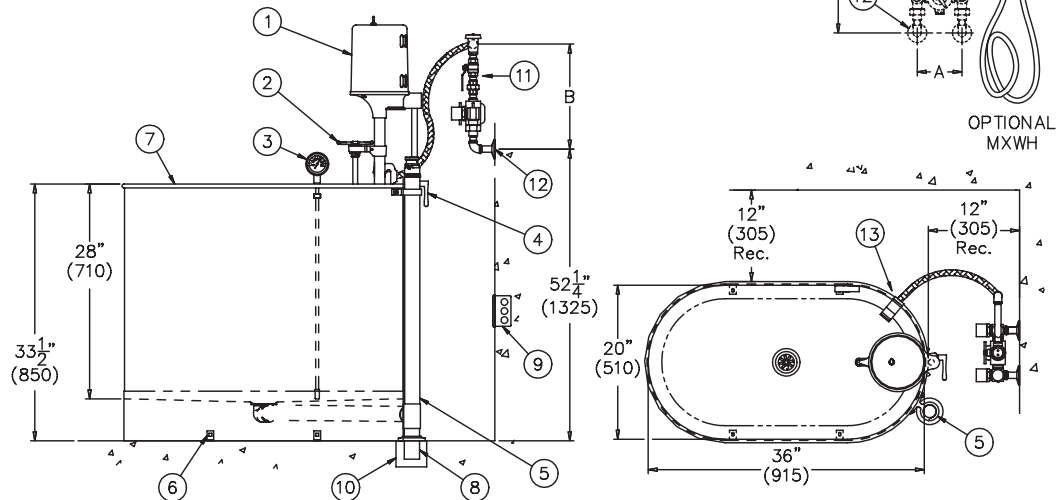

STATIONARY H-60-S SERIES WHIRLPOOL

NOTES:

- | | | |
|---|-------------------------------------|---|
| 1. 1/2 hp Jet Pump Motor. | 6. "L" Brackets -Four Each. | 10. Floor Drain by Others. |
| 2. Variable Pressure Control. | 7. Stainless Steel Tank. | 11. Optional Thermostatic Mixing Valve with Vacuum Breaker. |
| 3. Thermometer. | 8. 2" O.D. x 5" Tail Piece. | 12. H & C Water Inlets by Others. |
| 4. Turbine Raising & Lowering Device. | 9. 3 Pole GFI Receptacle by Others. | 13. Filler Spout. |
| 5. Combination Drain & Overflow Assembly. | | |

SELECTION SUMMARY & APPROVAL FOR MANUFACTURING

Model Number & Options _____ Quantity _____

Company _____ Date _____

Contact _____ Title _____

Approval for Manufacturing/Signature _____