

ATLANTA™

Operation Manual &
Product Specification



Seating Matters™

A close-up photograph of a grey castor wheel on a black chair base. A green lever is extended from the side of the wheel's housing, indicating it is engaged. A curved arrow points from the text box to this lever.

WANT TO GO STRAIGHT?

Ensure to engage directional lock castor at front left of chair

This Operation Manual is frequently updated to ensure safe use of your product. Visit www.seatingmatters.com where you can find a free copy of the most up to date version.

CONTENTS

- 2. Safety instructions
- 4. Technical Specification
- 5. User Guide and Operating Instructions
- 9. Working Environment
- 10. Seating Matters Recycling Policy
- 11. Intellectual Property
- 11. Maintenance and Servicing

SAFETY INSTRUCTIONS

All instructions must be read and understood before the product may be used.

Terminologies

Patient: The person sitting in the chair.

User: Competent person with responsibility for the persons sitting in the chair as well as the suitability of the equipment for the Patient. The User is responsible for checking the chair for faults during the course of its use.

Assembly, Installation, Warnings & Hazards.

1. This chair should be fully assembled, all fixings secured and the chair checked for safety by a competent person before use.
2. The User must ensure that the product is in good condition before use (check all nuts and bolts are fastened, fabric in good condition etc). If there are any problems, these must be reported to your Seating Matters provider and corrected before the chair is put into use.
3. Keep all body parts away from the mechanisms under the chair. Repairs and maintenance should only be carried out by fully trained technicians.
4. Exercise care in using the release lever for the reclining mechanisms and adjustments to avoid injury.
5. Pressure ulcer or pressure injury reduction is not a guarantee with this equipment. The User must ensure that the Patient has a period out of the chair after prolonged sitting to raise tissue oxygenation levels. Although the chair offers pressure management, the body tissue still needs time to recover. In many places, local or national guidelines recommend a maximum of 2 hours sitting at any one time. You must also observe Patient specific recommendations and guidelines as set by their health professional with regard to the use of tilt and recline for appropriate pressure management.
6. The product must be used on a level, plain, hard surface with the brakes engaged to avoid it moving during use and to ensure stability. When the chair is not in transit, all the braking castors on the product must be engaged to prevent risk of injury when being used.

7. The product may not be left in an outdoor environment. More information on fabrics and their environment can be found later in this manual.
8. A competent person, trained in the use of the chair, should make adjustments and set it up according to the User requirements and Patient dimensions before the Patient sits in the chair. Where possible, adjustments should be made when the Patient is not in the chair to avoid injury to the User and Patient.
9. Ensure there is more than one competent person there when making adjustments to ensure they are correct and safe for the Patient.
10. If in doubt as to any the adjustments, feel free to contact Seating Matters direct at technical@seatingmatters.com.
11. Under no circumstances must the User or Patient stand or sit on the footplate of the chair.
12. The chair should not be transported in a vehicle while the Patient is seated on the chair.
13. This product should not be lifted at any time unless by competent persons trained in such manual handling.
14. When operating the leg rest and recline features on the chair please ensure there is a 450mm gap around the chair to prevent the back or leg rest coming into contact with a wall or any other object.
15. On powered options, please ensure that your chair is charged daily.

Please call your Seating Matters provider if you have any questions on these points.

ATLANTA™

TECHNICAL SPECIFICATION

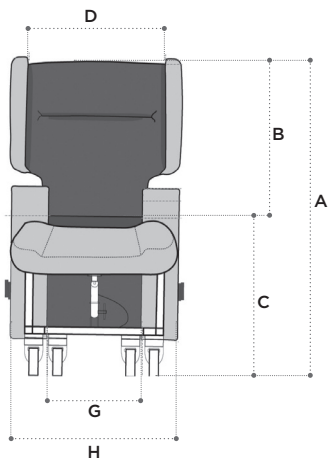

Basic dimensions

A	Overall height	1135mm/45in
B	Back height	750mm/30in
C	Seat height	540mm/21in
D	Inside back width	505mm/20in
E	Overall length	1350mm/53in
F	Reclined length	1700mm/67in

Available seat and overall widths

G (Seat width)	H (Overall width)
380mm/15in	635mm/25in*
450mm/18in	690mm/27in*
500mm/20in	690mm/27in*
550mm/22in	740mm/29in*
600mm/24in	790mm/31in*

* Dimension includes legrest belt. Deduct 35mm/1.5in if belt is not used.

Arm height options

I	Low	630mm/25in
J	High	660mm/26in

Seat depth

K	480mm/19in
----------	------------

Leg rest length

L	420mm/16.5in
----------	--------------

Clearance Height

M	75mm/3in
----------	----------

Recline and tilt angles

ii Back angle recline

110° - 140°

30° range

iii Leg rest angle

75° - 107°

32° range

iv Integrated tilt and recline

54° - 74°

20° range

Chair weight unloaded is 67 Kg/147.71 lb/10.56 Stone.
Chair user weight limit is 159 Kg/364 lb/25 Stone

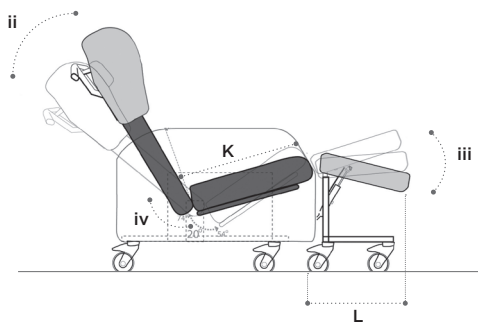
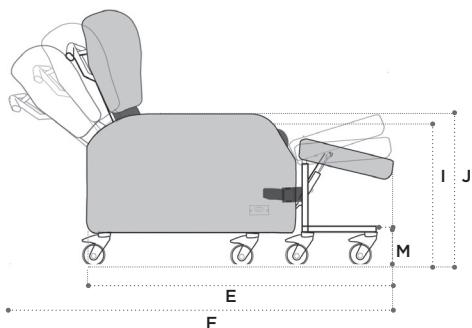

USER GUIDE AND OPERATING INSTRUCTIONS



- **Braking castors:** The ATLANTA™ chair must be used on a plane, hard surface with the brakes engaged to ensure stability and to avoid the device moving undesirably during use. Braking castors, where provided, must be in the braked position while in use. (fig.1) A competent person, trained in the use of the chair, should make adjustments and set it up according to the User requirements and Patient dimensions before seating the Patient. Ensure there is more than one competent person there when making adjustments to ensure they are correct and safe for the Patient. Ensure all fixings are secure before allowing the person to sit in the chair. Please call your Seating Matters provider if you have any questions on these points. This product should not be lifted at any time unless by competent persons trained in manual handling.

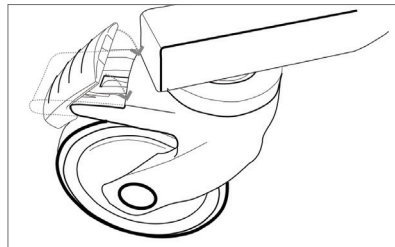

- **Tilt and recline:** To operate the integrated tilt and recline on the chair, the User must inform the Patient then stand behind the chair and with two hands, firmly hold the push handle while closing the release lever. (fig.2 & 2a) Move the back of the chair slowly until it is in the required position and allow the release lever to move to its relaxed position before letting go of the push handles.

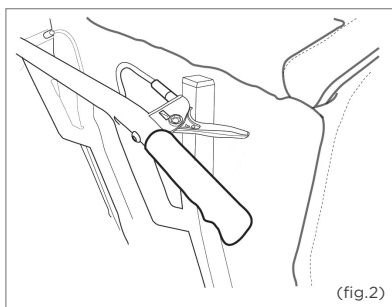

- **Chair movement:** To move the chair around, ensure that the back is in a fully upright position and push using the push handle on the back. Only a competent person should move this chair.

- **Leg Rest:** A variable angle leg rest can be used with the ATLANTA™ chair. When the leg rest is used, please ensure that it is attached securely onto the chair using the buckle attachments on both arms of the chair. (fig.3a) Ensure that only the weight of the Patient's legs are placed on this leg rest. Do not sit on the variable angle leg rest.

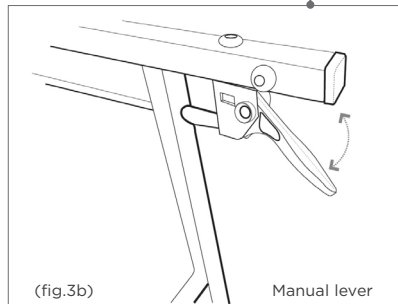
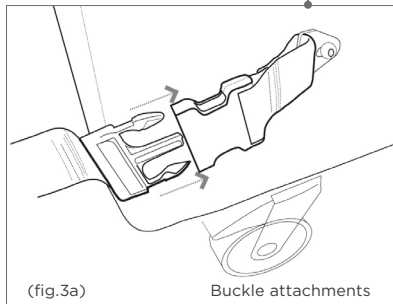
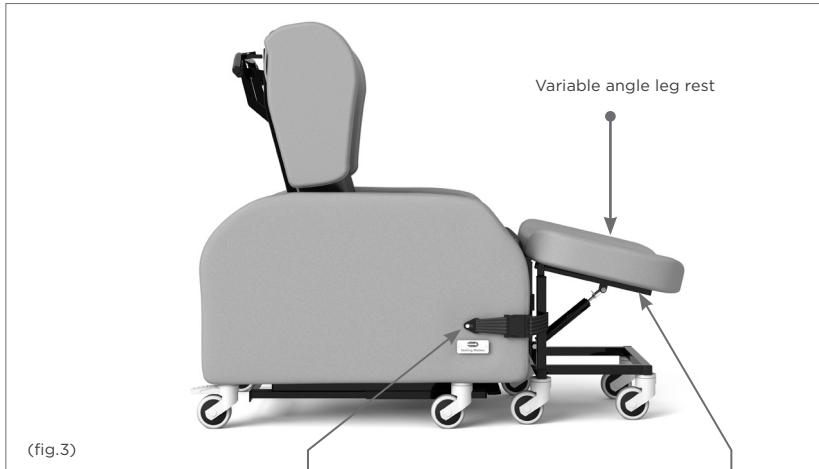

Before changing the angle of leg rest, the User or Patient must ensure there are no objects in the immediate environment that could obstruct the leg rest elevation or come into contact with the Patient's legs. Using the manual lever located under the front of the leg rest, move the leg rest until it is in the required position and release the lever. (fig.3b)



- **Sliding Footplate:** To use the sliding footplate, pull it out to the full position and allow the feet to rest on it, ensuring that the feet are placed on top of the sliding footplate. (fig.4) At no point should anyone stand or sit on the sliding footplate. Push the footplate in to its fully retracted position before allowing the Patient to get on or off the chair, exercising care to stay away from the sliding rail move the footplate by holding the front lip.
- **Stand Transfers:** For those who stand transfer, ensure the footplate is pushed in to its fully retracted position before allowing the Patient to get on or off the chair, exercising care to stay away from the sliding rail, move the footplate by holding the front lip. Use the integrated tilt and back recline to bring the chair up to a safe position for the Patient and perform the stand transfer. At no point should anyone stand or sit on the footplate.
- **Seat cushion:** The seat cushion on the ATLANTA™ is a waterproof, pressure reducing, breathable, medium foam cushion can be added for pressure relief and comfort in the chair. The seat cushion will have Velcro on one face and a zip closure to the rear. To fit the seat cushion to the chair, ensure the Velcro is on the bottom and makes contact with the Velcro already on the base board, with the zip closure at the rear. This is important as the foam's structure allows good immersion and envelopment of the body ONLY when fitted as instructed.

WORKING ENVIRONMENT

- **Dartex Multi Stretch Fabric:** (Central patient contact surface). Waterproof, stain resistant, flame retardant, multidirectional stretch for pressure redistribution i.e. seat cushion, calf panels, lateral supports and seat back.
- **Vinyl:** (Coloured material on non-patient contact surfaces). Non-absorbent, anti-bacterial, flame retardant, strong, durable material for outer arms, outside back etc.

Cleaning and Maintenance of Fabrics

- **Vinyl: Stain Resistance:** Vinyl is resistant to urine, most household stains, mild acids/alkalis, drinks and beverages as they are not absorbed and can be wiped off without any problem or lasting damage. Some difficult substances such as lipstick, ball point pen ink and food colourings should be cleaned off immediately to avoid permanent staining.

Dartex Multi Stretch Fabric (Patient contact surface)

Properties: This fabric is waterproof, has the ability to be wiped clean and has biostatic (anti-mycotic) coatings to provide an impenetrable barrier to virus and bacteria. Superficial dirt may be removed by wiping with a soft cloth moistened with water containing a neutral detergent. More persistent contamination may be treated by wiping with alcohols or turpentine substitute, followed by hot water and detergent. Routine cleaning and disinfection may be carried out on the coating with hand hot water and a neutral detergent or with a sodium hypochlorite solution (0.1% or 1000 parts per million available chlorine). The material is compatible with the 10,000ppm available chlorine in solution required for the decontamination of blood spills. Excess solution must be removed and the surface thoroughly rinsed and dried prior to reuse or storage. Proprietary disinfectants may be used provided manufacturer's instructions are followed. All cleaning agents, and disinfectants, must be thoroughly rinsed off and the item dried before storage.

Failure to do this may result in damage to the polyurethane coating, react with the chair frame, or negate the biocompatibility results of the fabric. It is essential that articles be thoroughly dried after all cleaning procedures and before storage.

SEATING MATTERS RECYCLING POLICY

Seating Matters are committed to reducing waste and improving our care for the environment. We aimed to construct our chairs with as many recyclable materials as possible that could be repurposed indefinitely.

The WEEE Directive

The WEEE Directive, 2012/19/EC, urges producers of Electrical and Electronic Equipment (EEE) to provide information on how these products can be treated, reused or recycled.

In order to comply with this directive in the European Union, Seating Matters electrical components are marked with a crossed out wheelee bin. This indicates that the electrical components should be treated in accordance with the WEEE regulations after their useful life.

Advice on Recycling

- Your Seating Matters product may contain batteries which should not be disposed of in household waste.
- Never dispose of the battery in a fire. This may cause an explosion.
- The product may contain substances that could be harmful to the environment.
- Electrical components must be taken to a proper recycling facility.
- Your Seating Matters product contains component parts which can be recycled.
- We thank you for being environmentally responsible and for making efforts to recycle your Seating Matters product at the end of its' safe and useful life.
- Contact your local authority or governmental agency for the regulations that apply in your area.
- If you wish to have Seating Matters recycle your product and your behalf, you are welcome to return the product to our company.

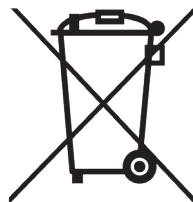

Plastic Components

Many of our plastic components are made from polypropylene and can be recycled as long as they are recycled with other polypropylene resin materials. Polypropylene sheets can be recycled with any other materials that have this symbol.



Plastic Trays

Our plastic tray tables are made from Polyethylene Terephthalate Glycol (PETG) which is a sturdy, transparent, easily cleaned material. Like acrylic, PETG is 100% recyclable and can be recycled and repurposed indefinitely. Capable of being sterilized, it's a renowned food-safe material and will help us meet a higher standard towards infection



prevention & control. PETG's damage resistance is far higher than that of acrylic & has an impact resistance 30 times that of glass. PETG can be recycled with any other materials that have this symbol.

Safety

Carelessness causes fire. The ATLANTA™ is CE marked to show conformance to the Medical Devices Directive 93/42/EEC and conforms to BS ISO 7176 at medium hazard.

Filling materials and covering fabrics meet the requirements for resistance to cigarette and match ignition in the 1988 safety regulations.

Regional Variations

The device referred to as a "ATLANTA™" is a Seating Matters product category and the information included in this document reflects common features of this group of products. In some regions of the world, we supply product design variations of similar function and ease-of-use but with alternative specifications or reinforcements.

INTELLECTUAL PROPERTY

Seating Matters are at the forefront of seating research and design, therefore we take the protection of our intellectual property very seriously and have our designs, patents and trademarks protected in many jurisdictions throughout the world. This is a list of some of our Intellectual property protections. This is not an exhaustive list.

- The Seating Matters Trademark is registered throughout the European Union and various countries globally.
- Patent Pending: No. GB1915470.7
- US Design Patent: No. 601360S, No. D611718; No. 600932, No. D602704S.
- Australian Design Registration: No. 325536, No. 324011, No. 325537, No. 324012.
- Community Design Registration: No. 001016364-002, No. 000942180-0004, No. 002428813-0001, No. 001016364-001, No. 012673018.
- Canadian Design Registration: No. 130224, No. 128763, No. 130217, No. 128764.

MAINTENANCE AND SERVICING

Regularly servicing your Seating Matters chair will prevent untimely and inconvenient breakdowns, reduce repair costs and extend the chair's life. Damage to the chair can also cause excess strain for the User and Patient.

Important

Parts can only be changed by service persons trained in Seating Matters products and use only Seating Matters parts. We recommend that your chair is serviced every year by a Seating Matters approved provider for any running repairs and maintenance.

Maintenance

Carry out the following regular checks to ensure the operation and safety of the chair. If you are in any doubt about the functioning of your chair contact your Seating Matters approved provider immediately.

Daily

- Check that the castors are not damaged.
- Check that the castors turn freely.
- Make sure that the castor forks run free and are not bent.
- Check all fabrics for damage or contamination and replace where necessary.
- See Cleaning and Maintenance of Fabrics section for cleaning instructions.
- Check batteries and electrical connections are secure.

Weekly

- Check the castor fittings for hair and dirt which could restrict the castor movement.
- Pick out any such material with tweezers or take the spindle out, clean it and then replace it.
- If it is still not free (one continuous turn without it sticking) contact your Seating Matters approved provider for a replacement.

Monthly

- **Castors:** Make sure the top of the castor housing is parallel with the floor. Any variation will cause restricted movement. If it is damaged contact your Seating Matters approved provider for replacement.
- **Mechanisms:**
 - Check all tilting mechanisms are working smoothly.
 - Check that cables are not kinked or frayed.
 - Check that all nuts and bolts are present.
 - Check that all nuts and bolts are secure.

Note: If nuts or bolts need attention, contact your Seating Matters approved provider **IMMEDIATELY** and **DO NOT USE** the chair until it has been serviced.

- **Leg rest:** Check that all leg rests are easily removed/swung-away and replaced or repositioned easily. Ensure that parts lock in place securely. If parts are not locking try lubricating. If the problem still remains contact your Seating Matters approved provider.
- **Frame:** Check the visible parts of the frame for cracks, splits, large dents or other damage. If you find any of these things **DO NOT USE**. Contact your Seating Matters





