



Store these instructions in a safe place or with the enclosed maintenance checklist

Instruction Sheet

OSCAR'S Playhouse 4400



Take time to familiarize yourself with the use and maintenance of this equipment before using. Please file this Instruction Sheet in an accessible location: the Instruction Sheet must be read and familiar to anyone who is using Southpaw Enterprises Equipment.

MATERIALS LIST

- 1 - Playhouse
- 1 - Instruction Sheet
- 1 - Maintenance checklist

SETUP INSTRUCTIONS

WALLS

Note: Each wall section has hook and loop fastener on three edges and vinyl on one edge. The edge with the vinyl is the bottom edge.

- Position the four sides as shown in Fig. 1. Make sure that the flaps are to the outside on each corner. If you have purchased the Playhouse Steps, determine where you want the steps to be and put the wall with the loop fastener on the side where you want the steps to be.
- Butt the loop edge of one side against the hook on the inside of the joining wall. Wrap the flap around the corner connecting the hook and loop fastener. Be sure that the flap completely covers the loop strip. Repeat this on all four corners.

Fig. 1

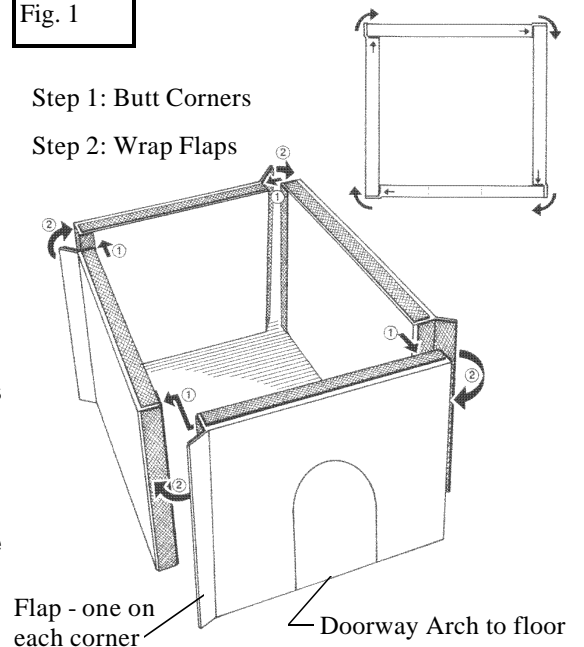

TOP

Note: Putting the top on your Playhouse requires two people.

- Position the top over the Playhouse with the hook fastener strips on the underneath side.
- Lower the top onto the walls of the Playhouse, aligning the edges of the top even with the outside edges of the walls.

Fig. 2

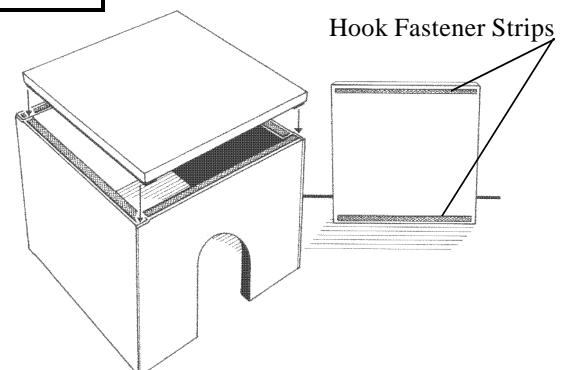

DOOR

- The removable door in the front of the Playhouse is secured with hook and loop fastener between the edges of the door and the wall.
- To remove the door, insert your hand between the wall and the door at the bottom. Work the hook and loop fastener loose while pulling out on the door until it is free.
- This is somewhat difficult but the door needs to be held securely when the Playhouse is inverted and used as a ball pool.

TO USE AS A BALL POOL

OSCAR'S Playhouse may be inverted and used as a ball pool with or without the door by having two people (one on each side) holding the top to the walls and turning the Playhouse onto its side, then onto its top.

MATTING PRECAUTIONS: Always use appropriate matting.

MAINTENANCE CHECKLIST

All of the following wear points should be checked on a monthly basis and recorded on the checklist enclosed.

- Check for torn vinyl and loose or ripped stitches. If tears or loose stitches are found, discontinue use until repaired.

STORAGE PROCEDURES

- Store where not accessible by clients without proper supervision.

CLEANING INSTRUCTIONS

- Check with your infectious disease department before using these procedures.
- Check for client allergies first.
- Clean with a damp cloth using mild soap and water or disinfectant.
- Dry before using.

Safety Precautions - The safety of your clients is dependent on the appropriate choice of activity to match, yet challenge their physical abilities. Use appropriate spotting / safety techniques. In addition, the layout of your activity area, proper installation and maintenance of your equipment is critical. Southpaw equipment is not intended for recreational or outdoor use. Under no condition should this equipment be used without proper supervision.

This sheet is for example only. It is not meant to, in any way, replace local, county, state, or Federal standards. Be aware - it is your responsibility to find all pertinent safety information that pertains to your facility.



Store these instructions in a safe place or with the enclosed maintenance checklist

Instruction Sheet

Playhouse Steps 4410



Take time to familiarize yourself with the use and maintenance of this equipment before using. Please file this Instruction Sheet in an accessible location: the Instruction Sheet must be read and familiar to anyone who is using Southpaw Enterprises Equipment.

MATERIALS LIST

- 1 - Playhouse Step
- 2 - Hook Strips to attach steps to Playhouse
- 1 - Instruction Sheet
- 1 - Maintenance Checklist

The Playhouse Steps are designed to be used with Southpaw's OSCAR'S Playhouse or Slide, but may be used by itself.

TO ATTACH STEPS TO PLAYHOUSE OR SLIDE

- The Playhouse Steps have two loop strips on one side that will line up with the two loop strips on the Playhouse or Slide.
- To attach the steps simply align the sides of the steps with the sides of the Playhouse or Slide and push them together.

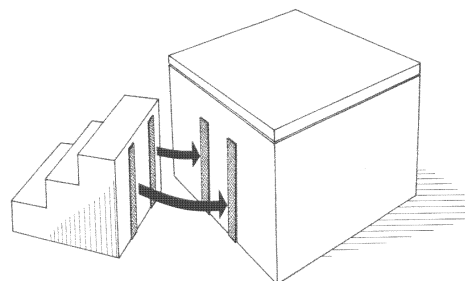

TO USE STEPS BY ITSELF

- When using the steps by itself, remove the two hook strips from the loop strips on the steps. This will leave the inoffensive loop exposed on the side of the steps.

MAINTENANCE CHECKLIST

All of the following wear points should be checked on a monthly basis and recorded on the checklist enclosed.

- Check for torn vinyl and loose or ripped stitches. If tears or loose stitches are found, discontinue use until repaired.

STORAGE PROCEDURES

- Store where not accessible by clients without proper supervision.

CLEANING INSTRUCTIONS

- Check with your infectious disease department before using these procedures.
- Check for client allergies first.
- Clean with a damp cloth using mild soap and water or disinfectant.
- Dry before using.

Safety Precautions - The safety of your clients is dependent on the appropriate choice of activity to match, yet challenge their physical abilities. Use appropriate spotting / safety techniques. In addition, the layout of your activity area, proper installation and maintenance of your equipment is critical. Southpaw equipment is not intended for recreational or outdoor use. Under no condition should this equipment be used without proper supervision.

This sheet is for example only. It is not meant to, in any way, replace local, county, state, or Federal standards. Be aware - it is your responsibility to find all pertinent safety information that pertains to your facility.



Store these instructions in a safe place or with the enclosed maintenance checklist

Instruction Sheet

Playhouse Slide 4420



Take time to familiarize yourself with the use and maintenance of this equipment before using. Please file this Instruction Sheet in an accessible location: the Instruction Sheet must be read and familiar to anyone who is using Southpaw Enterprises Equipment.

MATERIALS LIST

- 1 - Playhouse Slide
- 1 - Instruction Sheet
- 1 - Maintenance Checklist

The Playhouse Slide was designed to be used with Southpaw's OSCAR'S Playhouse or Playhouse Steps, but may be used by itself.

TO USE WITH PLAYHOUSE

This is best accomplished with two persons.

Step 1: Position Playhouse Slide beside the Playhouse with the Playhouse top removed.

Step 2: Raise the slide end flap.

Step 3: Push the slide towards the Playhouse to a point that the slide end is flush with the Playhouse wall.

Step 4: Lower the slide end flap onto the loop fastener on the top of the wall and press down to secure.

Step 5: Put the top back on the Playhouse.

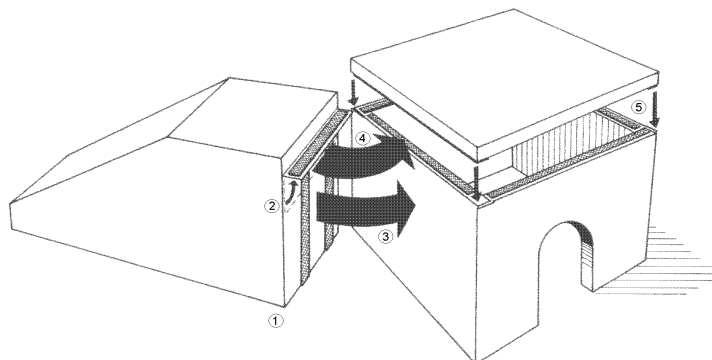

TO USE WITH PLAYHOUSE STEPS

With the hook strips attached to the strips on the Playhouse Steps, push the end of the steps against the end of the slide, aligning the hook and loop fasteners. Push the two units firmly together.

MAINTENANCE CHECKLIST

All of the following wear points should be checked on a monthly basis and recorded on the checklist enclosed.

- Check for torn vinyl and loose or ripped stitches. If tears or loose stitches are found, discontinue use until repaired.

STORAGE PROCEDURES

- Store where not accessible by clients without proper supervision.

CLEANING INSTRUCTIONS

- Check with your infectious disease department before using these procedures.
- Check for client allergies first.
- Clean with a damp cloth using mild soap and water or disinfectant.
- Dry before using.

Safety Precautions - The safety of your clients is dependent on the appropriate choice of activity to match, yet challenge their physical abilities. Use appropriate spotting / safety techniques. In addition, the layout of your activity area, proper installation and maintenance of your equipment is critical. Southpaw equipment is not intended for recreational or outdoor use. Under no condition should this equipment be used without proper supervision.

This sheet is for example only. It is not meant to, in any way, replace local, county, state, or Federal standards. Be aware - it is your responsibility to find all pertinent safety information that pertains to your facility.



southpaw enterprises, inc.®

Store these instructions in a safe place or with the enclosed maintenance checklist

Instruction Sheet

Playhouse Connector 4401



Take time to familiarize yourself with the use and maintenance of this equipment before using. Please file this Instruction Sheet in an accessible location: the Instruction Sheet must be read and familiar to anyone who is using Southpaw Enterprises Equipment.

MATERIALS LIST

1 - Playhouse Connector 1 - Instruction Sheet 1 - Maintenance Checklist

The Playhouse Connector is designed to secure two or more Playhouses together when using multiple Playhouses. One Connector is required to join two Playhouses, and an additional Connector for each additional Playhouse added.

TO CONNECT TWO PLAYHOUSES

- Place the two Playhouses with the tops removed together keeping in mind the position of the walls in regard to adding steps or slide.
- The Connector has hook fastener on one side and loop fastener on the other side. Place the Connector Strip with the loop (fuzzy or smooth side) facing up along the tops of the adjoining walls of the two Playhouses and press down on the Connector to secure it to the tops of the walls.
- Replace the tops on the Playhouses.

MAINTENANCE CHECKLIST

All of the following wear points should be checked on a monthly basis and recorded on the checklist enclosed.

- Check for torn vinyl and loose or ripped stitches. If tears or loose stitches are found, discontinue use until repaired.

STORAGE PROCEDURES

- Store where not accessible by clients without proper supervision.

CLEANING INSTRUCTIONS

- Check with your infectious disease department before using these procedures.
- Check for client allergies first.
- Clean with a damp cloth using mild soap and water or disinfectant.
- Dry before using.

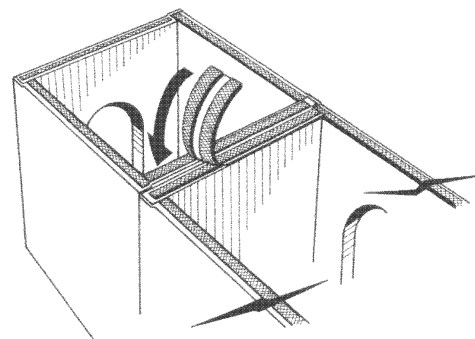

Safety Precautions - The safety of your clients is dependent on the appropriate choice of activity to match, yet challenge their physical abilities. Use appropriate spotting / safety techniques. In addition, the layout of your activity area, proper installation and maintenance of your equipment is critical. Southpaw equipment is not intended for recreational or outdoor use. Under no condition should this equipment be used without proper supervision.

This sheet is for example only. It is not meant to, in any way, replace local, county, state, or Federal standards. Be aware - it is your responsibility to find all pertinent safety information that pertains to your facility.