

# **MTD 4000**

## **Mettler Traction Decompression Instruction Manual**

*Distributed by:*

**M**ETTTLER **≡**LECTRONICS®  
corp.

1333 South Claudina Street  
Anaheim, CA 92805, U. S. A.

Toll free: (800) 854-9305 • Telephone: (714) 533-2221 • FAX: (714) 635-7539  
Web Site: <http://www.mettlerelectronics.com> • Email: [mail@mettlerelectronics.com](mailto:mail@mettlerelectronics.com)



# Table of Contents

<b>Section</b>	<b>Title</b>	<b>Page</b>
<b>1</b>	<b>Introduction</b>	<b>5</b>
1.1	Introduction to the MTD 4000	5
1.2	Introduction to This Manual	5
1.3	Safety Precautions	6
1.4	Caution	6
1.5	Shipping Damage	6
1.6	Package Contents	6
1.7	Limited Warranty	6
<b>2</b>	<b>Symbol Glossary and List of Abbreviations</b>	<b>9</b>
2.1	Symbol Glossary	9
2.2	List of Abbreviations	9
<b>3</b>	<b>Indications, Safety Concerns, Contraindications and Precautions</b>	<b>11</b>
3.1	Indications	11
3.2	Safety Concerns	11
3.3	Contraindications	12
3.4	Precautions	12
<b>4</b>	<b>Controls and Functions</b>	<b>13</b>
4.1	Front View	13
4.2	Bottom View	13
4.3	Side View	14
4.4	Rear View	14
4.5	Control Panel	15
<b>5</b>	<b>Installation</b>	<b>17</b>
5.1	Installation Instructions	17
5.2	Installation Notes	18
5.3	Changing the Factory Settings	20
5.3.1	Changing the Force Units (F-0)	20
5.3.2	Changing the MIDI Music Selection (F-1)	21
5.3.3	Changing the MIDI Music Volume	21
<b>6</b>	<b>Operating Instructions</b>	<b>23</b>
6.1	General Operating Instructions	23
6.2	Setting Up the Continuous Mode	23
6.3	Setting Up the Intermittent Mode	24
6.4	Changing Parameters During Treatment in the Continuous Mode	24
6.5	Changing Parameters During Treatment in the Intermittent Mode	25
6.6	Changing Modes During a Treatment	26
6.7	Saving a Treatment Setup	26
6.8	Recalling a Saved Treatment Setup	26
<b>7</b>	<b>Maintenance and Troubleshooting</b>	<b>27</b>
7.1	Cleaning the MTD 4000	27
7.2	Routine Maintenance	27
7.3	Error Codes	27
7.4	Troubleshooting the MTD 4000	28
<b>8</b>	<b>References</b>	<b>29</b>
<b>9</b>	<b>Specifications</b>	<b>31</b>
<b>10</b>	<b>Accessories</b>	<b>33</b>
10.1	Ordering Information	33
10.2	MTD 4000 Accessories	33

# Illustrations

<b>No.</b>	<b>Title</b>	<b>Page</b>
1.1	The MTD 4000	5
4.1	Front View of the MTD 4000	13
4.2	Bottom View of the MTD 4000	13
4.3	Side View of the MTD 4000	14
4.4	Rear View of the MTD 4000	14
4.5	Control Panel	15
5.1	Bottom View of the MTD 4000 Showing Placement of Mounting Holes	17
5.2	Rear View of the MTD 4000 Showing Connectors and Switches	18
5.3	F-0 Controls and Displays	20
5.4	F-1 Controls and Displays	21
5.5	F-2 Controls and Displays	21
6.1	Continuous Mode Display	23
6.2	Intermittent Mode Display	24
6.3	Saving a Treatment Setup	26

# Section 1: Introduction

## 1.1 Introduction to the MTD 4000

Thank you for purchasing the MTD 4000 (Mettler Traction Decompression) system from Mettler Electronics Corp. The microprocessor controlled MTD 4000 provides cervical or lumbar traction by exerting therapeutic pulling forces on the patient's body with enhanced reliability and ease of use.

The MTD 4000 system is an easy to use device that offers static, intermittent, and cyclic traction with user definable hold, rest, and treatment times. It gently pulls the cervical spine or lumbar spine in opposite directions to draw the soft tissue around the cervical or lumbar joints and separate the distance between bone sections of the vertebra.

The MTD 4000 may be used to help relieve peripheral radiation/sciatica and pain associated with: herniated discs, spinal root impingement, bulging discs, hypomobility, protruding discs, degenerative disc disease, degenerative disc disease, facet syndrome, posterior facet syndrome, compression fractures, acute facet problems, radicular pain, discogenic pain and prolapsed discs.

Some of the features of the MTD 4000 are:

- ◆ Easy to use
- ◆ Active displays show all treatment parameters and progress.
- ◆ Multiple sensors and safety controls
- ◆ High strength traction cable
- ◆ Smooth, quiet operation
- ◆ Fits almost any existing table platform
- ◆ Clinician can save up to ten treatment setups
- ◆ Adjustable Hold/Rest times
- ◆ Continuous and Intermittent traction with multiple speed selection
- ◆ Two year limited warranty



Figure 1.1—The MTD 4000

## 1.2 Introduction to This Manual

Read the contents of this manual prior to treating patients with the MTD 4000.

This manual has been written to assist you with the safe operation of the MTD 4000. It is intended for use by the owners and operators of the MTD 4000. The goal of this manual is to direct the correct operation and maintenance of this unit.

The specifications and instructions presented in this manual are in effect at the time of its publication. These instructions may be updated at any time at the discretion of the manufacturer.

### 1.3 Safety Precautions

The MTD 4000 operates with high voltages. Servicing of the MTD 4000 should be performed by qualified biomedical technicians with training in traction service or it should be returned directly to the factory. To maximize safety during use, the unit should be plugged into a grounded wall outlet of proper voltage.

Service may be obtained from the manufacturer by sending the MTD 4000 in its original shipping container to: Mettler Electronics Corp., 1333 South Claudina Street, Anaheim, CA 92805, ATTN: Service Department. (Telephone toll free: (800) 854-9305) This service may also be performed by qualified biomedical engineers or technicians trained in traction calibration.

NOTE: All warranty repairs must be performed by Mettler Electronics Corp. or by a service facility authorized by Mettler Electronics to perform warranty repair work.

### 1.4 Caution

Federal law restricts the sale of this device to, or on the order of a physician, dentist, veterinarian or any other practitioner licensed by law of the state in which he practices.

Use of controls or adjustments or performance of procedures other than those specified herein may result in hazardous exposure to traction forces. Treatment should be administered only under the direct supervision of a health care professional.

### 1.5 Shipping Damage

Your new MTD 4000 is shipped complete in one carton. Upon receipt, please inspect the carton and the unit for visible and hidden damage. If any damage is discovered, hold all shipping materials, including the carton, and call the shipping agent who delivered the unit.

The carton in which your new MTD 4000 was received is specially designed to protect the unit during shipping. Please retain all shipping materials in the event that you will need to return your unit for servicing.

NOTE: All repairs must be performed by Mettler Electronics Corp. or by a service facility authorized by Mettler Electronics to perform repair work.

### 1.6 Package Contents

Your new MTD 4000 comes complete with all the necessary components to perform traction therapy. Below is a list of items that are included in the shipping carton.

1. MTD 4000
2. Patient safety switch (ME 40001)
3. Traction cable with hook (ME 40002)
4. Detachable, hospital grade line cord, (ME 40003)
5. Four long and four short mounting screws and four split washers
6. Instruction Manual

### 1.7 Limited Warranty

The MTD 4000 generating unit is warranted against defects in materials and workmanship for a period of two years from date of purchase. During the applicable warranty period Mettler Electronics Corp. will, at its discretion, either repair or replace the Product without charge for these types of defects.

For service under this warranty, the Product must be returned by the buyer within the applicable warranty period to Mettler Electronics Corp. **Shipping charges to and from Mettler Electronics Corp. under this warranty must be paid by the buyer. The buyer must also include a copy of the sales receipt or other proof of the date of purchase. If the Product is returned without proof of the date of purchase, it will be serviced as an out-of-warranty product at Mettler Electronics Corp.'s prevailing service rates.**

**Alteration, misuse, or neglect of the Product voids this warranty. Except as specifically set forth above, Mettler Electronics Corp. makes no warranties, express or implied, including without limitation any implied warranty of merchantability or fitness for a particular purpose, with respect to the Product. If any implied warranties apply as a matter of law, they are limited in duration to one year.**

**Mettler Electronics Corp. shall not be liable for any indirect, special, consequential or incidental damages resulting from any defect in or use of the Product.**

Any legal action brought by the buyer relating to this warranty must be commenced within one year from the date any claim arises and must be brought only in the state or federal courts located in Orange County, California.











Some states do not allow limitations on how long an implied warranty lasts, or the exclusion or limitation of incidental or consequential damages, so the above limitations or exclusions may not apply to the buyer. This warranty gives the buyer specific legal rights, and the buyer may also have other rights which vary from state to state.

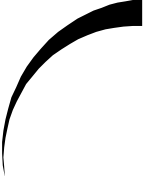



# Section 2—Symbol Glossary and List of Abbreviations

## 2.1 Symbol Glossary

	Power On.
	Power Off.
	Time symbol
<b>Min</b>	Minutes
<b>Sec</b>	Seconds
	Adjust time and force settings
	Continuous mode symbol
	Intermittent mode symbol
	Start symbol
	Stop symbol
	Attention, consult Accompanying Documents
	Refer to the instructions
	Type BF Equipment—Class I

## 2.2 List of Abbreviations

A	—	Amperes
Kg	—	kilograms
Lb	—	pounds
LED	—	Light Emitting Diode
Min	—	Minutes
RH	—	Relative Humidity
Sec	—	Seconds
Ser No.	—	Serial Number
V	—	Volts
W	—	Watts



# Section 3 — Indications, Safety Concerns, Contraindications and Precautions

## 3.1 Indications

The MTD 4000 traction device provides traction and mobilization of skeletal structures and skeletal muscles.



The MTD 4000 may be used to relieve peripheral radiation/sciatica and pain associated with:





- Protruding discs
- Bulging discs
- Herniated discs
- Degenerative disc disease
- Posterior facet syndrome
- Acute facet problems
- Radicular pain
- Prolapsed discs
- Spinal root impingement
- Hypomobility
- Degenerative joint disease
- Facet syndrome
- Compressions fractures
- Joint pain
- Discogenic pain

The MTD 4000 achieves these effects through decompression of intervertebral discs, that is, unloading due to distraction and positioning.

## 3.2 Safety Concerns

**Be cautious of the following when setting up or using the MTD 4000:**

	<p>Read this operation manual carefully before treatment.</p> <p>Please contact Mettler Electronics Corp. if this operation manual is incomplete.</p> <p>If the MTD 4000 functions or operates abnormally, please contact Mettler Electronics Corp. or your distributor for service.</p> <p>Clinicians should instruct their patients to power off device by pressing the patient safety switch, if they experience any discomfort.</p> <p>The MTD 4000 may be susceptible to interference originating from shortwave or microwave diathermy devices operating in close proximity to it. Avoid operating the MTD 4000 adjacent to and simultaneously with operating shortwave or microwave devices.</p> <p>When a traction session is completed, clean the harness, table and chair, which came in direct contact with patient's skin according to the manufacturer's cleaning instructions.</p> <p>Avoid use of the MTD 4000 in unclean environments.</p> <p>When the MTD 4000 is in use, make certain to maintain good ventilation around the unit to avoid heat buildup. Avoid use of this device on soft or uneven surfaces since that may potentially block the ventilation holes.</p> <p>When you are not using this device, place it in the Standby mode to save power.</p> <p>Avoid spilling liquids into the unit. This may damage the device or harm the patient.</p> <p>Avoid using this device in conjunction with other equipment on the same patient.</p>
	<p>Power off and remove power cord before cleaning the MTD 4000.</p>

	<p>Do not store in direct sunlight.  <b>Warning:</b> The MTD 4000 may be susceptible to interference originating from shortwave diathermy units operating in close proximity to it. Avoid operating the MTD 4000 adjacent to and simultaneously with operating shortwave devices.</p>
	<p>Please use device in a dry environment. Water, steam, and other liquids will have significant deleterious effects on the electronic components.</p>
	<p>When using an extension cord with this device, do not use the same extension cord with other devices simultaneously to prevent surges, shorts, and possible electrically-caused fires.</p>
	<p>Please do not open the MTD 4000. Mettler Electronics reserves the right to repair and service only unopened devices.</p>

### 3.3 Contraindications

	<p>Do not use traction on patients with structural disease due to tumors or infection (e.g., osteomyelitis, spinal caries, and ankylosingspondylitis).</p> <p>Do not use on patients with joint instability, hypermobility or spinal fracture.</p> <p>Do not use traction on patients with osteoporosis.</p> <p>Traction should not be administered to individuals who are or may be pregnant.</p> <p>Do not use on patients with severe cardiovascular disease, vascular compromise, aortic aneurysm or severe respiratory disease.</p> <p>Do not use traction on patients where movement is contraindicated.</p> <p>Do not use on patients with acute sprains, strains or inflammation that could be aggravated by traction.</p> <p>Stop traction if there is an increase in radiated pain to the extremities (radicular pain).</p> <p>Do not use lumbar traction on patients with hiatal or abdominal hernias.</p>
--	---

### 3.4 Precautions

	<p>Use caution on using traction on patients with claustrophobia.</p> <p>Take precautions when using cervical traction on patients with TMJ or dentures.</p> <p>Use care on patients who do not tolerate prone or supine positions, they may not be good candidates for traction therapy.</p>
---	---

# Section 4— Controls and Functions

## 4.1 Front View

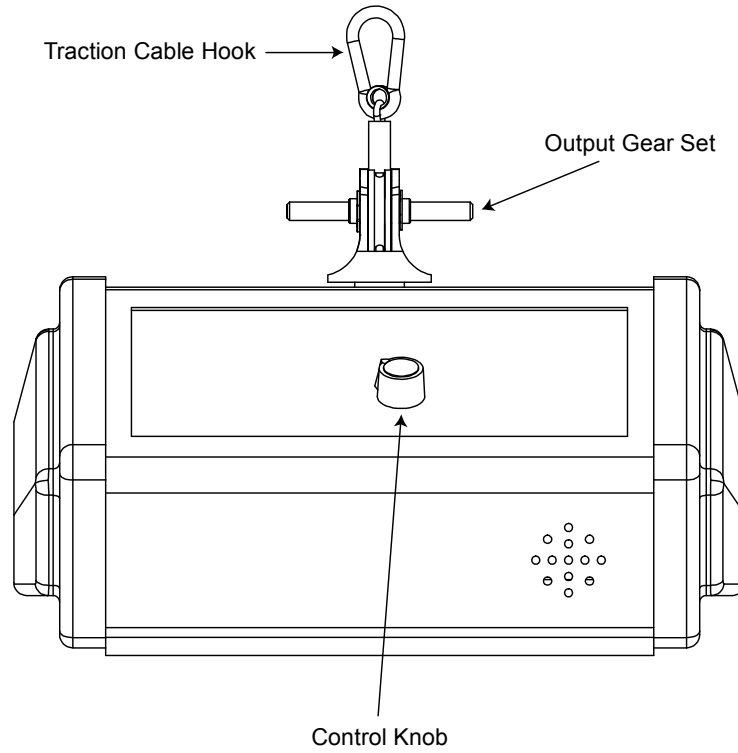

Figure 4.1—Front view of the MTD 4000

## 4.2 Bottom View

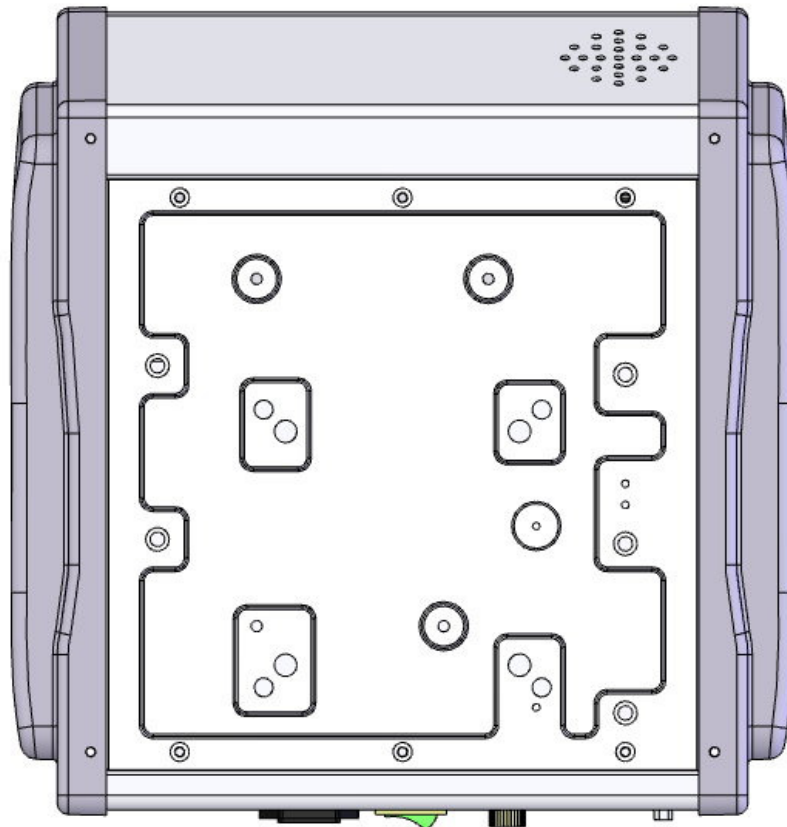

Figure 4.2—Bottom view of the MTD 4000

### 4.3 Side View

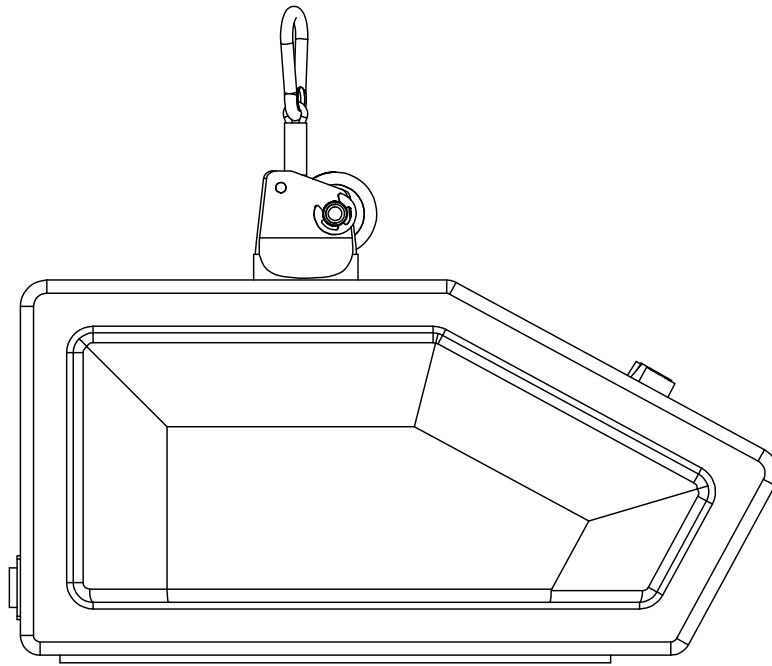

Figure 4.3—Side view of the MTD 4000

### 4.4 Rear View

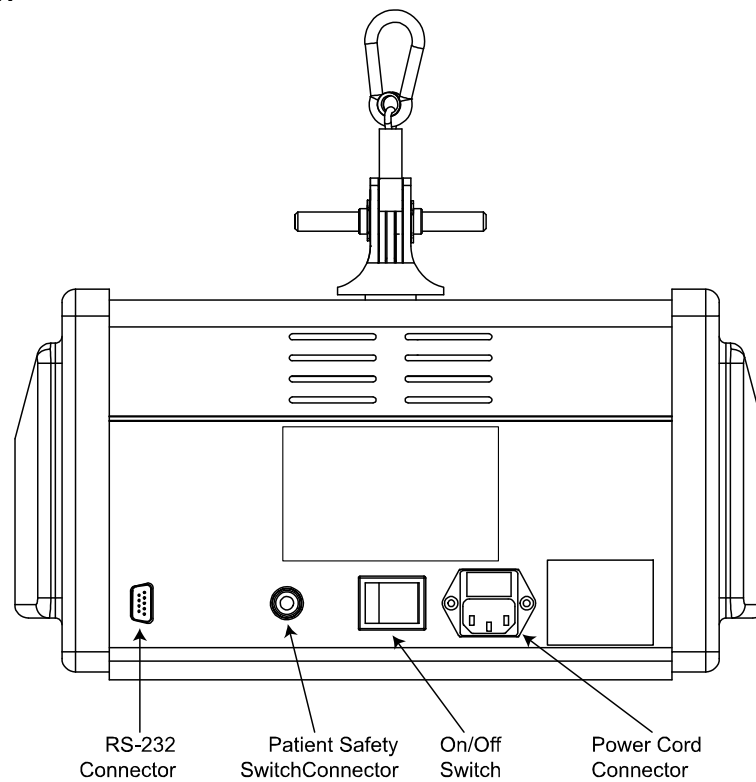

Figure 4.4—Rear view of the MTD 4000

4.5 Control Panel

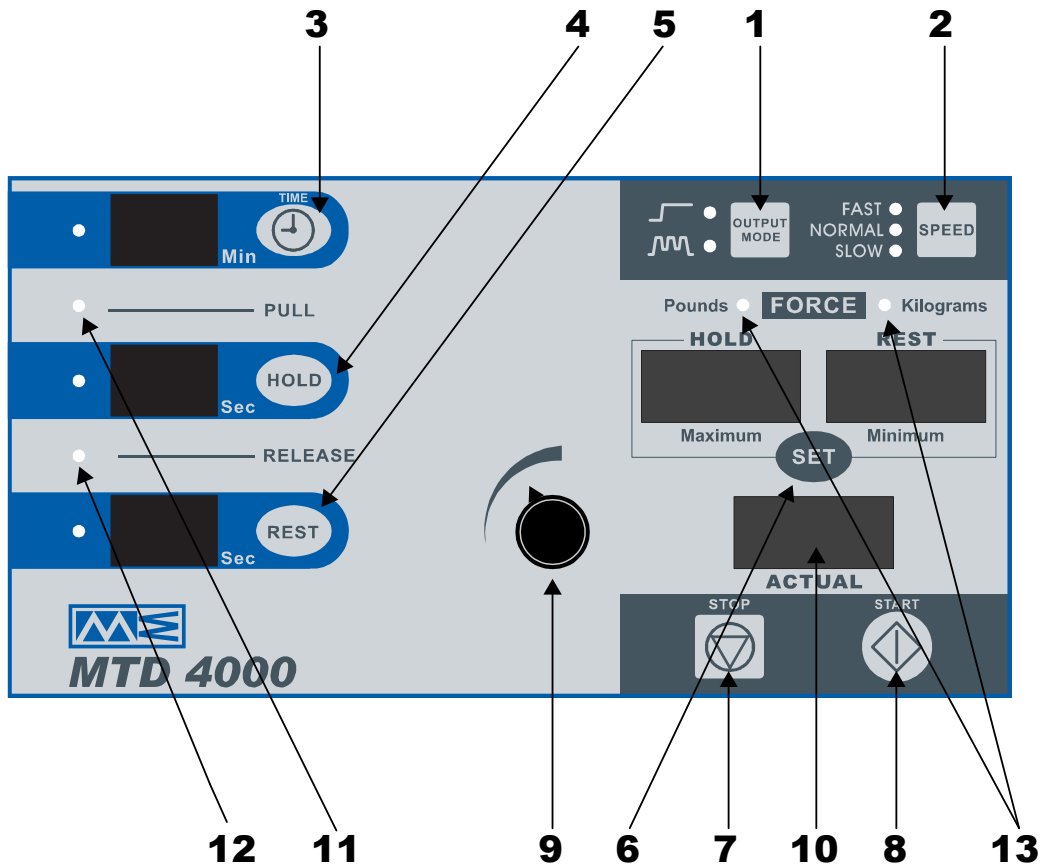







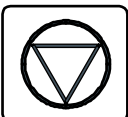
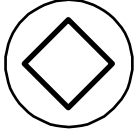

Figure 4.5—Control Panel

Number	Control	Description
1		Press this button to switch between Continuous Mode and Intermittent Mode. (  stands for Continuous Mode;  stands for Intermittent Mode.) When using Continuous Mode, some non-applicable settings such as HOLD and REST times, will not be illuminated.
2		Press this button to set traction speed. There are three speeds – FAST, NORMAL, and SLOW.
3		Press this button to set treatment time. The digital display flashes after the button is pressed. Turn the control knob to set treatment time from 1 to 99 minutes. The left LED indicator will keep flashing during treatment time.
4		Press this button to set pull strength hold time. The digital display will flash after the button is pressed. Turn the control knob to set hold time from 1 - 99 seconds. The left LED indicator lights during hold time.
5		Press this button to set pull strength rest time. The digital display flashes after the button is pressed. Turn the control knob to set rest time from 1 - 99 seconds. The left LED indicator lights during rest time.
6		Press this button to set strength. Hold & Rest setting can be exchanged upon pressing the button. Turn the control knob to set strength (HOLD : 2 - 90 kg / 4 - 198 lb ; REST : 0 - 89kg / 0 - 195 lb).
7		Press this button to stop traction.

**8**

**START**



Press this button to start traction.

**9**



Control knob — To increase or decrease the value of a setting. (Clockwise→ Increase; Anti-clockwise→ Decrease.)

**10**

The column shows the actual output value during the treatment.

**11**

When the device starts to increase the pulling strength, the PULL indicator lights.

**12**

When the device starts to decrease the pulling strength, the RELEASE indicator lights.

**13**

Lb / Kg indicator: The force units being used on the device.

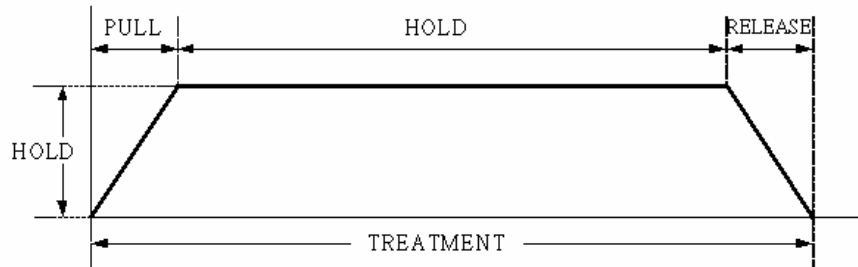

Continuous Mode

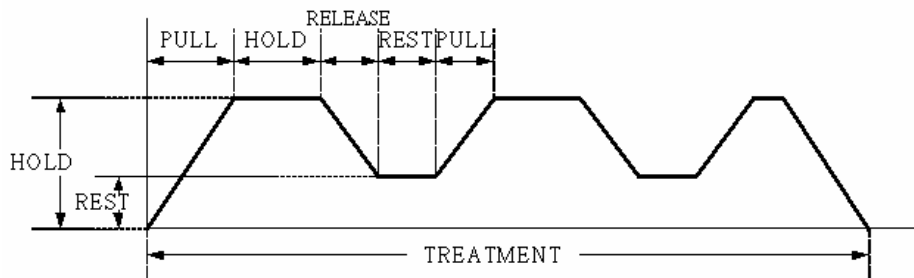

Intermittent Mode



# Section 5—Installation

## 5.1 Installation Instructions

1. Attach the MTD 4000 to the table using the accompanying hardware supplied with the unit. (See Figure 5.1) Please note, lower right hand mounting hole requires short mounting screw. An example with step by step instructions is shown below:

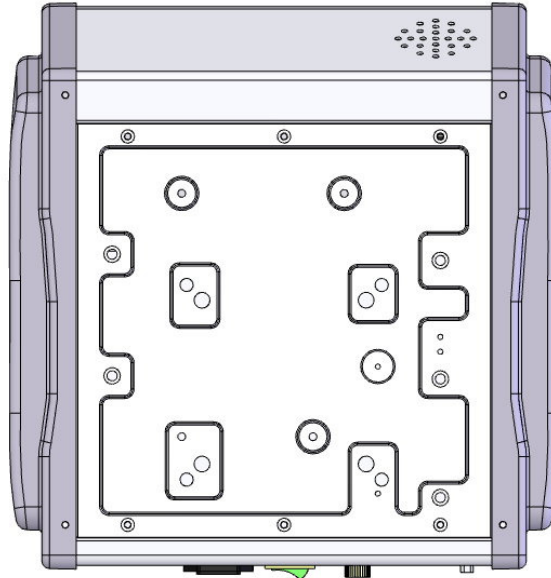

Figure 5.1— Bottom View of the MTD 4000 Showing Placement of Mounting Holes



2. Center MTD 4000 on table platform.
3. Position bolts using the bolts provided with the MTD 4000.
4. Tighten bolts with  $\frac{1}{2}$  in wrench or socket.
5. Loosen platform slide retainer bolt.



6. Push platform to opposite side.

7. Position and tighten bolts.

8. Connect the line cord to the back of the MTD 4000. (See Figure 5.2)
9. Plug the line cord into a grounded wall outlet that is rated at AC 110V~120V, 50/60Hz (other voltages available). Your mains power supply must match the voltage requirements listed on the serial number label of your device.
10. **Do not connect the MTD 4000 to a power supply rated differently than that described above.** The unit comes equipped with a grounded line cord. This plug provides grounding for the MTD 4000. Do not defeat its purpose by using adapters or any other means of attaching to a wall outlet.

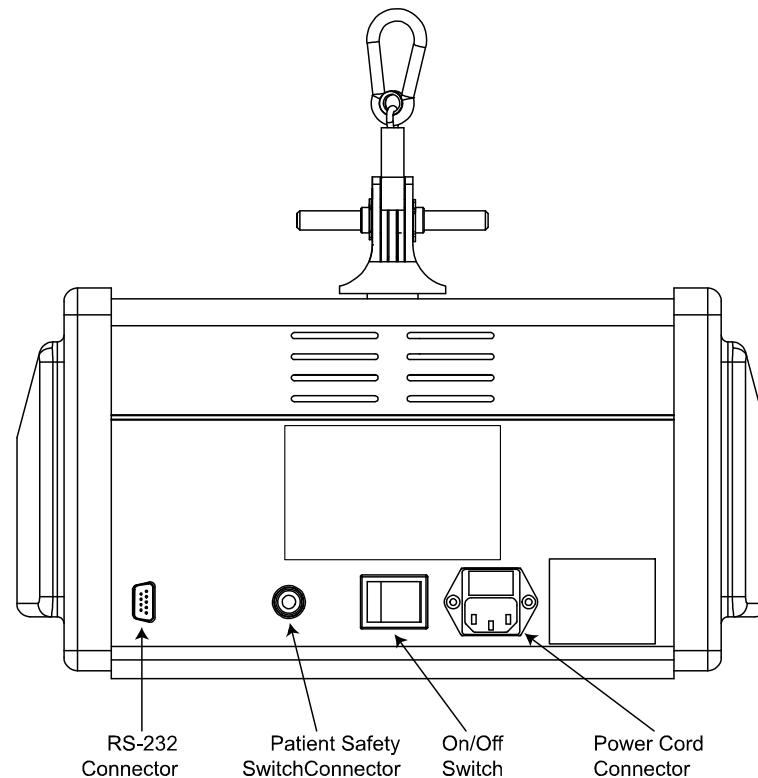





Figure 5.2— Rear View of the MTD 4000 Showing Connectors and Switches

11. Plug the patient safety switch into the back of the unit.
12. Attach the desired harness for either lumbar or cervical traction.

13. Pictured below are the accessories that come with the MTD 4000.

 <p>MTD 4000</p>	 <p>One Power Cord (40003)</p>
 <p>One Patient Safety Switch (40001)</p>	 <p>Eight Mounting Screws and Four Split Washers</p>

14. The accessories shown below are only for reference. Your distributor may supply other accessories for use with this device.

 <p>Lumbar traction showing traction belt</p>	 <p>Lumbar traction showing traction belt</p>
 <p>Lumbar traction showing traction belt and positioning acc.</p>	 <p>Cervical traction showing clevis and traction harness</p>

## 5.2 Installation Notes

1. Do not pull the traction cable exceeding the red mark on the cable.

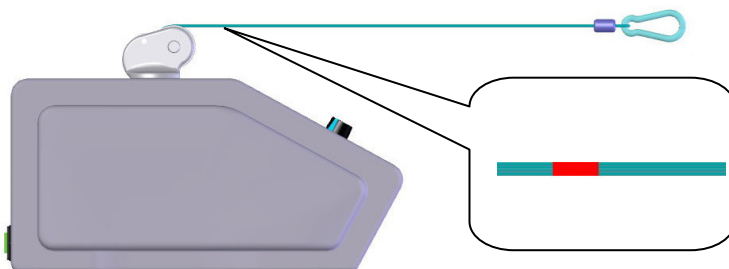

2. Only pull the traction cable in the correct direction as shown below.

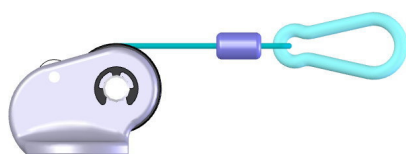

Correct

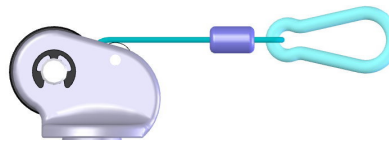

Incorrect

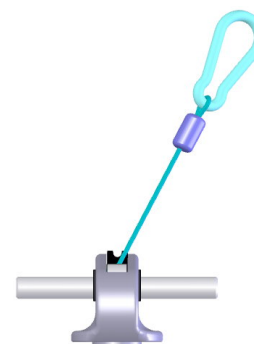

Incorrect

## 5.3 Changing the Factory Settings

1. Turn the MTD 4000 off.
2. Hold the “Set” button down while you turn on the power at the rear of the unit.
3. Continue to press and hold down the set button at least 3 seconds. The system will enter “Factory Setting Mode” and display “F-0” in the “Actual” display window as shown in Figure 5.3.

### 5.3.1 Changing the Force Units (F-0)

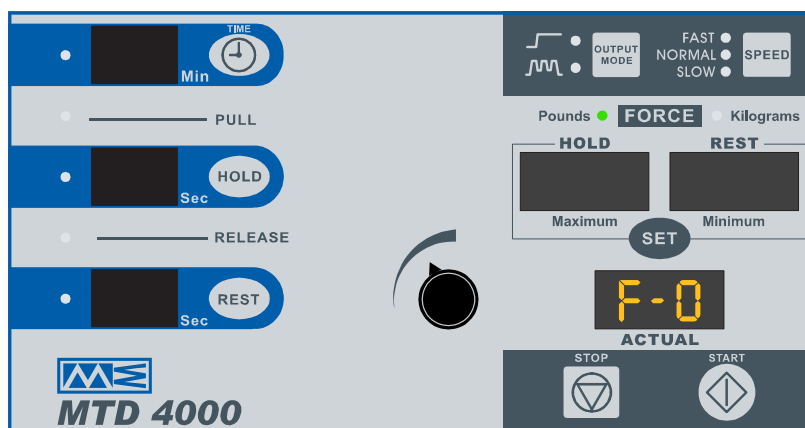

Figure 5.3— F-0 Controls and Displays

1. Make sure the device is under Factory Setting Mode, showing an “F-?” in the “Actual” display window.
2. Turn the control knob until “F-0” is displayed in the “Actual” display window and press the start button to select the “F-0” code. Press the set button to switch to a different traction force unit “LB” or “KG”. The new setting will be automatically saved.



START



SET



3. Press the “Stop” key to leave the factory setting mode and return to normal operation.

### 5.3.2 Changing the MIDI Music Selection (F-1)

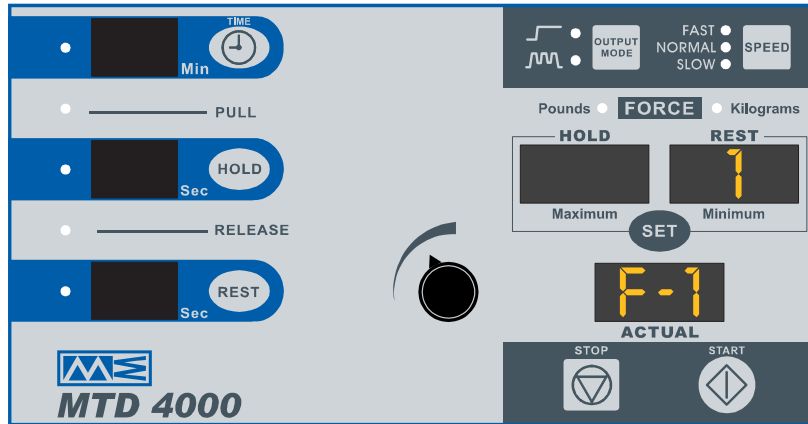

Figure 5.4— F-1 Controls and Displays

1. Make sure the device is under Factory Setting Mode, showing an “F-?” in the “Actual” display window.
2. Turn the control knob until “F-1” is displayed in the “Actual” display window and press the start button to select the “F-1” code.



START



3. Turn the control knob to choose a different MIDI music selection.



START



4. Press the start button to save new setting.



STOP

5. Press the “Stop” key to leave the factory setting mode and return to normal operation.

### 5.3.3 Changing the MIDI Music Volume (F-2)

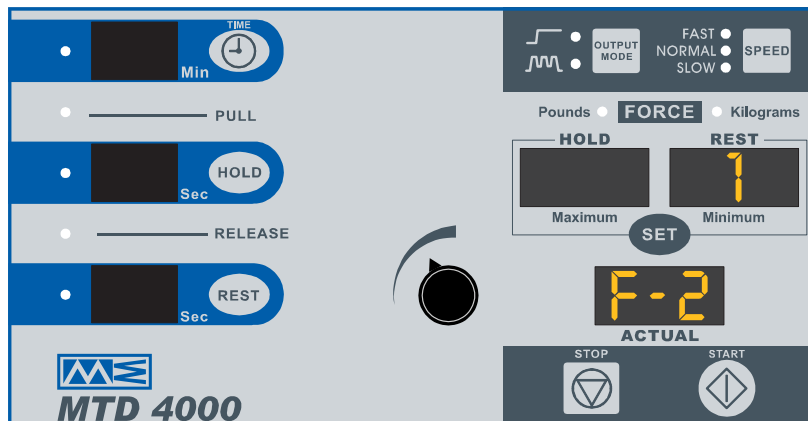

Figure 5.5— F-2 Controls and Displays

1. Make sure the device is under Factory Setting Mode, showing an “F-?” in the “Actual” display window.
2. Turn the control knob until “F-2” is displayed in the “Actual” display window and press the start button to select the “F-2” code.



START



3. Turn the control knob to change the MIDI music volume.



START



4. Press the start button to save new setting.



STOP

6. Press the “Stop” key to leave the factory setting mode and return to normal operation.

# Section 6—Operating Instructions

## 6.1 General Operating Instructions

Before you start:

- Review precautions and contraindications in Section 3.
- Verify connection of the line cord to a grounded wall receptacle and the MTD 4000.
- Make sure the patient safety switch is attached and handed to the patient.
- Note: MTD 4000 will display E-4 if patient safety switch is not attached.
- Note: Descriptions of the symbols used on controls are in Section 2.
- Note: Detailed descriptions of controls and connections are in Section 4.

- Turn the power on.
- The automatic startup test will run for 1~2 seconds.
- After test completion, the user can proceed with normal parameter setting.

## 6.2 Setting up the Continuous Mode

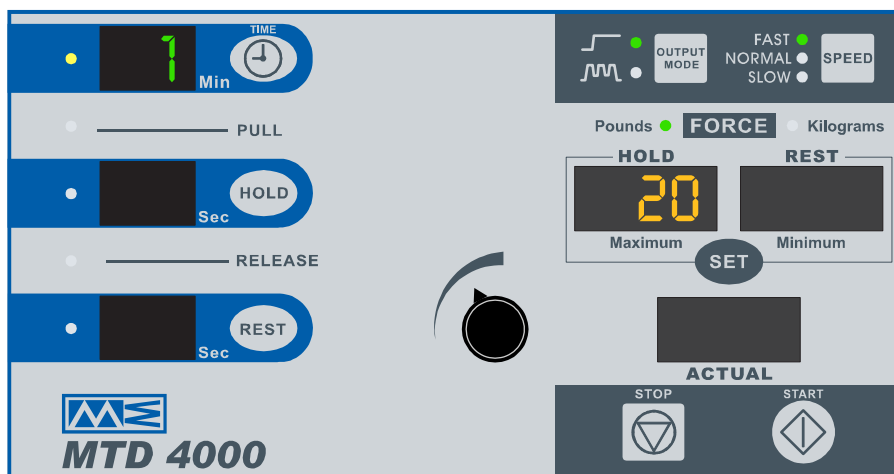



Figure 6.1—Continuous Mode Display



- Press the output mode button to set the MTD 4000 to the continuous mode. The LED next to  should be lit.



- Press the set button to set traction force. The “Hold” display will start flashing. Turn the control knob to set the desired value. Press the set button again to save the Hold value.  
**NOTE:** When an indicator is flashing, no key press within 10 seconds will cause the flashing to automatically stop.



- Press the time button to set the treatment time. The timer display will start flashing. Turn the control knob to set the desired time in minutes. Press timer button again to save the time. Flashing stops once the time is saved.



- Press the speed button to set traction speed (**FAST/NORMAL/SLOW**).



- Press the start button. All parameter settings are confirmed and the treatment starts.

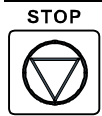

- Press the stop button to stop treatment and release the traction force. The system will revert to Normal Setting status.

**NOTE:** The patient can press the “Patient Safety Button” to stop treatment and release the traction force if any discomfort is experienced during the treatment. The alarm buzzer will sound and the display will show an error code “E-4”. To revert to a safe status “E-4” can be removed by pressing the stop button.

### 6.3 Setting up the Intermittent Mode

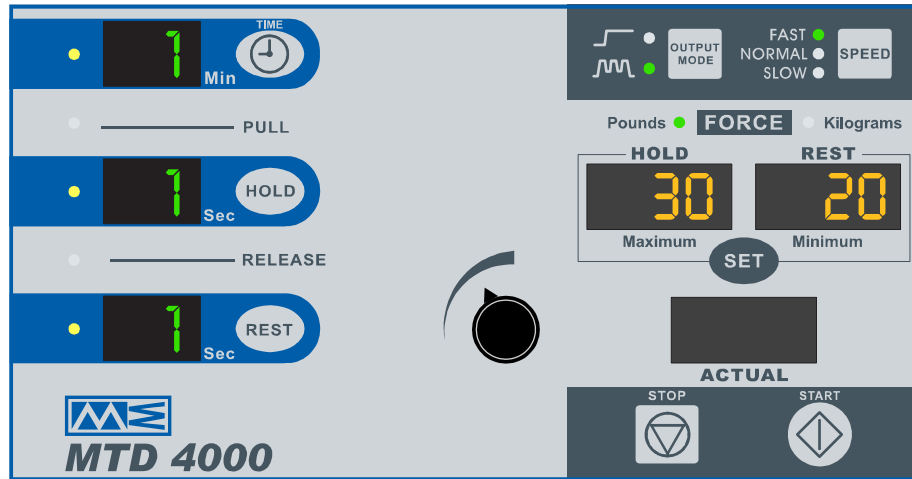
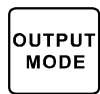



Figure 6.2—Intermittent Mode Display



- Press the output mode button twice to set the MTD 4000 to the intermittent mode. The LED next to  should be lit.



- Press the set button to set traction force. The “Hold” display will start flashing. Turn the control knob to set the desired force value. Press the set button again to save the Hold force value. Then the “Rest” display will start flashing. Turn the control knob to set the desired rest force value. Press the set button again to save the rest force value. **NOTE:** When an indicator is flashing, no key press within 10 seconds will cause the flashing to automatically stop.



- Press the time button to set the treatment time. The timer display will start flashing. Turn the control knob to set the desired time in minutes. Press timer button again to save the time. Flashing stops once the time is saved.



- Press the hold button to set the hold time. The hold display will start flashing. Turn the control knob to set the desired hold time in seconds. Press hold button again to save the hold time. Flashing stops once the hold time is saved.



- Press the rest button to set the rest time. The rest display will start flashing. Turn the control knob to set the desired rest time in seconds. Press timer button again to save the rest time. Flashing stops once the rest time is saved.



- Press the speed button to set traction speed (**FAST/NORMAL/SLOW**).





7. Press the start button. All parameter settings are confirmed and the treatment starts.



8. Press the stop button to stop treatment and release the traction force. The system will revert to Normal Setting status.

9. **NOTE:** The patient can press the “Patient Safety Button” to stop treatment and release the traction force if any discomfort is experienced during the treatment. The alarm buzzer will sound and the display will show an error code “E-4”. To revert to the operational status, “E-4” can be removed by pressing the stop button.

## 6.4 Changing Parameters during Treatment in the Continuous Mode



1. While a treatment is running, press the set button to adjust the traction force. The unit beeps and the “Hold” display will start flashing. Turn the control knob to set the desired force value. Press the set button again to save the hold force value. Any other parameters may be changed at this time. Press the start button to confirm the new setting and resume treatment. **NOTE:** When an indicator is flashing, no key press within 10 seconds will cause the flashing to automatically stop.



2. While a treatment is running, press the time button to adjust treatment time. The unit beeps and the timer display will start flashing. Turn the control knob to set the desired time. Press the time button again to save the time. Press the start button to confirm the new setting and resume treatment.



## 6.5 Changing Parameters during Treatment in the Intermittent Mode



1. While a treatment is running, press the set button to adjust traction force. The unit beeps and the “Hold” display will start flashing. Turn the control knob to set the desired force value. Press the set button again to save the hold force value and adjust the rest force value. After the rest force value is set, press the set button. Any other parameters may be changed at this time. Press the start button to confirm the new setting and resume treatment. **NOTE:** When an indicator is flashing, no key press within 10 seconds will cause the flashing to automatically stop.





2. While a treatment is running, press the time button to adjust treatment time. The unit beeps and the timer display will start flashing. Turn the control knob to set the desired time. Press the time button again to save the time. Press the start button to confirm the new setting and resume treatment.



## 6.6 Changing Modes during a Treatment



1. Press the output mode button until you have selected either the continuous or the intermittent mode. Either the LED next to  (continuous) or  (intermittent) should be lit.
2. Either go to 6.2 for the continuous setup procedure or to 6.3 for the intermittent mode setup procedure.

## 6.7 Saving a Treatment Setup

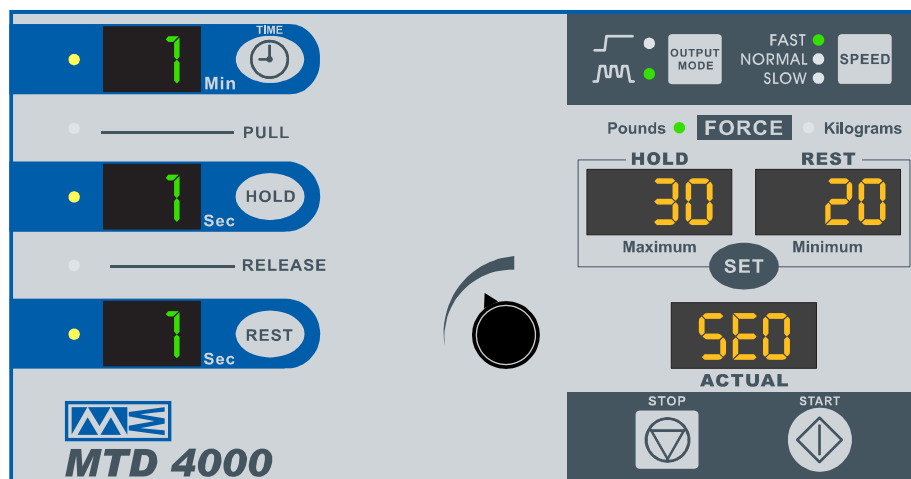

Figure 6.3—Saving a Treatment Setup

1. Set the desired treatment parameters using either section 6.2 for the continuous mode or section 6.3 for the intermittent mode.
2. Press the stop button repeatedly (at least 5 times in 5 seconds) until “Actual” display window shows “SE0”. You have entered the memory function mode.
3. Press the set button to save the treatment setup to “SE0” memory and to exit the save function.
4. There are a total of 10 memory slots: “SE0” through “SE9”. As an example, to save a treatment setup in the “SE8” position, after step 2, turn the control knob until the actual display window shows “SE8”, then press the set button to save the treatment setup and to exit the save function.



## 6.8 Recalling a Saved Treatment Setup

1. Press the stop button repeatedly (at least 5 times in 5 seconds) until “Actual” display window shows “SE0”. You have entered the memory function mode.
2. Turn the control knob until the actual display window shows whichever treatment setup you would like to use, “SE0” through “SE9”.
3. Once the code for the treatment setup you would like to use is displayed in the “Actual” display window, press the start button to select it. The code will blink to show that it has been selected.
4. Press set to select that code and start the treatment.
5. The treatment is ready to go, so press the “Start” button to begin the treatment.

# Section 7—Maintenance and Troubleshooting

## 7.1 Cleaning the MTD 4000

1. The MTD 4000 can be wiped off with a damp cloth. The power cord should be disconnected from the unit before this is done. In the case of stubborn dirt a gentle household cleaner can be sprayed on the cloth and then wiped on the unit. If this method is used, remove any cleaner residue with a damp cloth. Do not spray cleaner onto the unit.
2. Do not use any cleaning agents containing high contents of phenol derivates, alcohol, compounds of chlorine or peracetic acid. It is recommended to use aldehyde-based disinfectants. The device is not suited for heat sterilization or for sterilization with gases.
3. Follow the manufacturer's instructions for cleaning all harnesses and treatment table surfaces after use on each patient.

## 7.2 Routine Maintenance

1. To assure accurate performance of the MTD 4000, calibration should be performed on an annual basis by a qualified biomedical technician.
2. Standard medical electrical safety checks should be performed annually by qualified biomedical engineers or technicians trained to perform these procedures.
3. Inspect the traction cable for wear. It should be replaced if signs of wear are noticed.
4. The manual calibration indicated in the instruction manual should be performed routinely.
5. Annually, the auto-calibration should be performed by a qualified biomedical technician.
6. Replace the traction cable every two years. This service should be performed by a qualified biomedical technician.

## 7.3 Error Codes

Error Code	Description	Cause of Error	Solution
E-1	EEPROM calibration data is wrong.	Did not implement calibration or the saved data was wrong; or Did not test limit switch function, or the limit strength data was wrong.	Send back to Mettler Electronics for repair.
E-2	Electro-magnet valve is damaged.	The valve is broken or improperly connected.	Send back to Mettler Electronics for repair.
E-3	Micro-switch of clutch is damaged.	Micro-switch has no signal or is damaged.	Send back to Mettler Electronics for calibration.
E-4	The patient safety switch has been pressed.	Nurse call button is pressed, removed, or improperly connected.	Check cable connection and press the stop button to remove the error code.
E-5	Pull strength reached limit.	The pull strength reached safety limit.	Reset the MTD 4000 by turning it off and then on again.
E-6	Load Cell communication has error.	Did not connect Load Cell or wrong setting.	Press the stop button to remove error code.
E-7	LTC1400 ADC has no signal or abnormal signal.	LTC1400 damaged or transmission cable improperly connected.	Send back to Mettler Electronics for calibration.

<b>E-8</b>	Sudden and abnormal pull strength.	A sudden strength in excess 3 kg and maintained for over 1 second.	Check cable connection and press the stop button to remove error code.
<b>E-9</b>	EEPROM non-calibration data is wrong.	Non-calibration data has been improperly saved.	Press the stop button to remove error code.
<b>E-A</b>	Detect Motor Performance	<p>Pulling or releasing takes longer than the default time, 50 seconds. This will happen if the patient is incorrectly strapped where traction forces cannot reach the set value.</p> <ul style="list-style-type: none"> <li>· Strap too loose.</li> <li>· Patient's body is not positioned appropriately on the table.</li> <li>· Motor non-conformance.</li> </ul>	<ul style="list-style-type: none"> <li>· Turn off.</li> <li>· Check table mechanism.</li> <li>· Re-strap patient.</li> <li>· Make sure the patient's body is appropriately positioned.</li> <li>· Turn on and try again</li> <li>· If E-A persists, send back to Mettler Electronics for repair.</li> </ul>

## 7.4 Troubleshooting the MTD 4000

Item	Description	Cause of Error	Solution
1	Fail to power on.	Fuse is broken.	Replace fuse.
		AC Power Cord is damaged.	Replace power cord.
		Transformer or main control board is damaged.	Contact Mettler Electronics for repair service.
2	No traction output or abnormal traction output.	Traction cable broken or mechanical parts broken.	Contact Mettler Electronics for repair service.
		Firmware error or calibration error.	Contact Mettler Electronics for repair service.
3	On/off switch or push button out of function.	Program is still running or the traction force is releasing.	Wait until the work is completed.
		Membrane or potentiometer is damaged.	Contact Mettler Electronics for repair service.
		The main control board is damaged or has a bad connection.	Contact Mettler Electronics for repair service.
4	No display or abnormal display.	The main control board is damaged or has a bad connection.	Contact Mettler Electronics for repair service.
		Display is damaged.	Contact Mettler Electronics for repair service.

**NOTE:** Please contact Mettler Electronics Corp. before taking any repair action. Please write down the software revision that appears in the “Actual Force” window during the power up procedure. Our service department may be reached at 800.854.9305 from 7 am until 3:30 pm Monday through Friday. You may also reach us via email at [service@mettlerelectronics.com](mailto:service@mettlerelectronics.com).

## Section 8—References

- \* Cameron, MH. *Physical Agents in Rehabilitation: From Research to Practice*, Saunders, Philadelphia, PA, 2003.
- \* Knight KL and Draper DO. *Therapeutic Modalities: The Art and Science*, Lippincott Williams & Wilkins. Baltimore, MD, 2008.
- \* Michlovitz SL and Nolan TP. *Modalities for Therapeutic Intervention*, F.A. Davis Co., Philadelphia, PA, 2005.
- \* Excellent overviews of therapeutic traction. Extensive bibliographies can provide more in-depth information if needed.

This manual has been written as a guideline for the correct use of the MTD 4000. Reading the above references will provide a more complete understanding of the correct use of therapeutic traction and decompression.



## Section 9—Specifications

Power Supply	AC 110V~120V, 50/60Hz AC 220V~240V, 50/60Hz
Power Consumption	100 W (Max.)
Fuse	2.0 A/ 250 V× 2 Slow Blow 1.0 A/ 250 V× 2 Slow Blow
Maximum Output Force	198 lb / 90 Kg
Output Force Tolerances	4 – 44 lb ± 2 lb 45 – 110 lb ± 3 lb 111 – 198 lb ± 4 lb
Traction Speed	Fast — ~5-6 Seconds to reach 90 kg. Normal — ~12-15 Seconds to reach 90 kg. Slow — ~22-25 Seconds to reach 90 kg.
Hold / Rest Period	1 - 99 Seconds
Treatment Time	1 - 99 minutes
Treatment Mode	Continuous / Intermittent
Security System	Error Codes E-1 - E-A
Display	Yellow / Green Digital LED Display
Patient Safety Switch	2 Pin connector, push button normally closed
Electromagnetic Compatibility	IEC 60601-1-2
Medical Device Classification	Class IIa as per MDD 93/42/EEC
Operation Temperature/Humidity	0~40°C / 90%RH under
Storage Temperature/Humidity	-20~60°C / 90%RH under
Dimension	L 14.2" × W 12.2" × T 9"
Net Weight	32 pounds





---

## Section 10—Accessories

### 10.1 Ordering Information:

Therapy products and accessories are available from Mettler Electronics authorized Distributors. For information regarding either Mettler products or a distributor near you, please call toll free, (800) 854-9305 or phone (714) 533-2221 in areas outside the continental United States. Ask for Customer Service. Mettler Electronics is open from 7 AM until 5 PM Pacific Time for your convenience. You may also reach Customer Service via email at [mail@mettlerelectronics.com](mailto:mail@mettlerelectronics.com).

### 10.2 MTD 4000 Accessories

<b>Catalogue #</b>	<b>Item Description</b>
40001	Patient safety switch
40002	Traction cable with hook
40003	Power cord for the MTD 4000, 110 V (domestic)
40004	Power cord for the MTD 4000, 220 V (international)

