

Instructions

TRANSITIONS® Modular Entry Ramp

Available in 1", 1½", 2", 3", 4", 5", and 6" heights

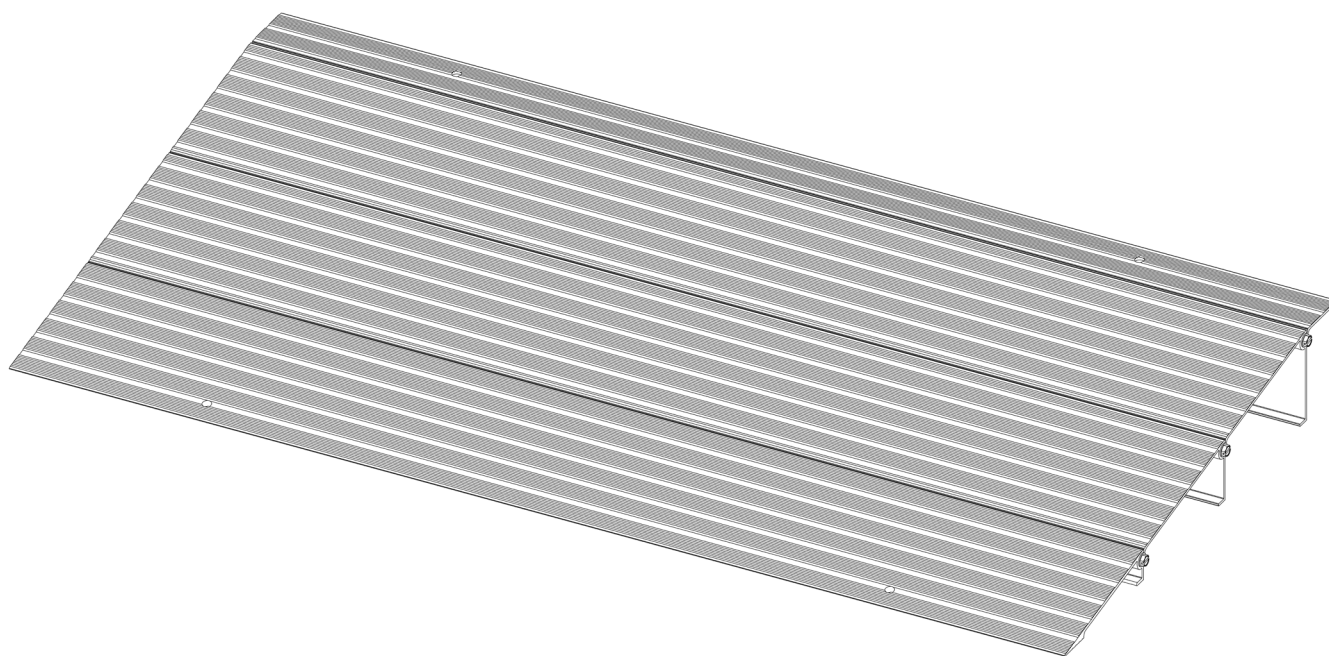

LIFETIME WARRANTY. Please register at www.ezaccess.com/warranty-satisfaction.
CE Technical Files kept at: 3 THE TROSSACHS, CLANCY STRAND, LIMERICK, V94 83H6, IRELAND
© EZ-ACCESS, a division of Homecare Products, Inc. All rights reserved.

All text and images contained in this document are proprietary and may not be shared, modified, distributed, reproduced, or reused without the express written permission of EZ-ACCESS®.



SYMBOLS

- ⚠ The **WARNING** symbol indicates a potentially hazardous condition/situation. The warnings throughout this document, and on your equipment, if any, are for the protection of people and property. Failure to abide by warnings will result in a waiver of all liabilities, loss of your warranty, and could result in equipment damage and or failure, property damage, risk of serious bodily injury, and or death to operators, riders, and those nearby. The symbol may appear in various colors and in conjunction with other symbols.

- 👉 The **NOTE** symbol indicates important information. Failure to obey all notes could result in improper operation, less-than-optimum equipment performance, and at the sole discretion of the equipment manufacturer, may void your warranty. The symbol may appear in various colors and in conjunction with other symbols and with or without the written word “NOTE”.

WARNINGS

- ⚠ Maximum weight capacity is 700 lbs.; never exceed weight capacity.
- ⚠ Prior to assembly and use, read and follow all instructions, warnings, and labels. Following all instructions and obeying all warnings before and during use is necessary for safe operation.

- ⚠ For people and mobility equipment only; not for commercial use.
- ⚠ Before use with mobility equipment, refer to your mobility equipment's owner guide for acceptable usage, including proper slope/incline, chair direction, etc.; never exceed its recommendations.
- ⚠ Use the ramp with a qualified helper as needed.
- ⚠ Always use a lap belt if using the ramp with mobility equipment.
- ⚠ Before each use, check the ramp for worn, loose, or damaged parts. If you find any of these conditions, do not use the ramp. Contact your dealer for service or repairs; failure to do so may cause injury.
- ⚠ Do not use the ramp if it is damaged or unstable.
- ⚠ Do not tamper with, attempt to repair, or modify any portion of the ramp.
- ⚠ Use caution when assembling and otherwise handling the ramp to avoid all potential pinch points.
- ⚠ Ensure that the landing ramp will be placed on is substantial and of sound construction.
- ⚠ Use only if the secure, unobstructed, level landing can support, at minimum, the same weight capacity as the ramp (700 lbs.).
- ⚠ Ensure that the ramp is used on a secure, unobstructed, level landing that is sound enough to safely install anchoring hardware, and that the ramp is flush against the raised landing. If a secure, unobstructed, level landing cannot be attained, or if the ramp is not flush against the raised landing, do not use the ramp.
- ⚠ Ensure that the ramp is securely anchored before each use.
- ⚠ Use only if sufficient maneuvering room is available at both ends of the ramp to assure safe travel when entering and exiting the ramp.
- ⚠ The ramp surface may be slippery in wet conditions; use caution if the surface is wet as traction may be reduced.
- ⚠ Do not use the ramp if its surface is covered with ice, snow, dirt, leaves, or other debris. Remove accumulations and sweep the surface clean before use.
- ⚠ Improper use of the ramp could result in serious injury.
- ⚠ Always exercise caution when handling, installing, and or using the ramp.

TOOLS AND HARDWARE TYPICALLY REQUIRED







- MEASURING TAPE
- POWER DRILL
- PHILLIPS HEAD SCREWDRIVER OR BIT
- 1/4" DRILL BIT
- 1/4" MASONRY DRILL BIT (IF ANCHORING INTO CONCRETE)
- HAMMER (IF ANCHORING INTO CONCRETE)
- SEMI-PERMANENT ANCHORING HARDWARE & TOOLS (SEE 'ANCHOR' SECTION)

1. **GETTING STARTED**

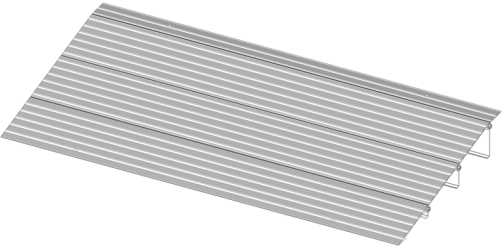
- 1.1 Read this instruction manual in its entirety before use and follow all instructions before and during use.
- 1.2 Before use with mobility equipment, refer to your mobility equipment's owner guide for acceptable incline usage, including proper slope/incline, chair direction, etc.; never exceed its recommendations.
- 1.3 Before each use, check the ramp for worn, loose, or damaged parts. If you find any of these conditions, do not use the ramp.
- 1.4 Confirm that all package contents are present. Open the shipping box and inspect for damaged or missing parts. If damaged or missing parts are noted, do not use the ramp.

2. **PACKAGE CONTENTS**

Package contents will vary depending on ramp size purchased.

QTY	DESCRIPTION	IMAGE (NOT SHOWN TO ACTUAL SIZE)
1	EZ-ACCESS® TRANSITIONS® MODULAR ENTRY RAMP <i>(TMER 3 SHOWN)</i>	
4	SCREW #10-24 X 1/2" THREAD CUTTING SLOTTED HEX WASHER HEAD SCREW <i>(If TMER 1, TMER 1.5, or TMER 2 was purchased)</i>	
8	SCREW #10-24 X 1/2" THREAD CUTTING SLOTTED HEX WASHER HEAD SCREW <i>(If TMER 3 or TMER 4 was purchased)</i>	
12	SCREW #10-24 X 1/2" THREAD CUTTING SLOTTED HEX WASHER HEAD SCREW <i>(If TMER 5 or TMER 6 was purchased)</i>	
4	SCREW 1/4" X 1" LONG SELF DRILLING, SELF TAPPING PAN HEAD PHILLIPS	
1	INSTRUCTIONS	

3. **COMPONENTS**

3.1 Components will vary depending on ramp size purchased; please refer to TABLE 1 and FIG. 1.

PART NO.	COMPONENTS / EXTENSIONS INCLUDED
TMER 1	1" Extension (Foot), Flap
TMER 1.5	1" Extension (Foot), 1.5" Extension, Flap
TMER 2	1" Extension (Foot), 2" Extension, Flap
TMER 3	1" Extension (Foot), 2" Extension, 3" Extension, Flap
TMER 4	1" Extension (Foot), 2" Extension, 3" Extension, 4" Extension, Flap
TMER 5	1" Extension (Foot), 2" Extension, 3" Extension, 4" Extension, 5" Extension, Flap
TMER 6	1" Extension (Foot), 2" Extension, 3" Extension, 4" Extension, 5" Extension, 6" Extension, Flap

TABLE 1

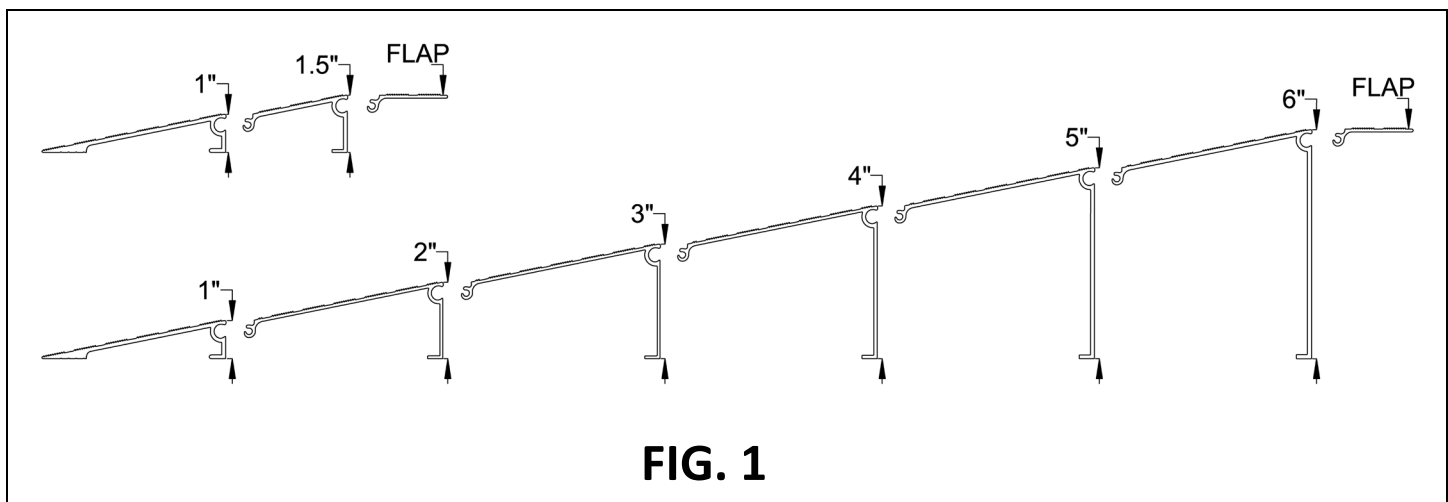

FIG. 1

4. **CARE AND MAINTENANCE**

- 4.1 Before each use, check the ramp for worn or damaged parts. If you find any of these conditions, do not use the ramp.
 - ⚠ Do not tamper with, attempt to repair, or modify any portion of the ramp.
- 4.2 Ensure that the ramp is always flush against the raised landing.
- 4.3 Before each use, tighten any loose fasteners.
- 4.4 Keep the ramp surface clear of ice, snow, dirt, leaves, and other debris. For ice and or snow, remove all accumulations and sweep surface clean. For dirt, leaves, and other debris, sweep surface or wash with a soft bristle brush and non-alkaline detergent, rinse well.
 - ⚠ The ramp surface may be slippery in wet conditions. Use caution if surface is wet as traction may be reduced.
- 4.5 Store the ramp in a cool, dry place when not in use.

5. **ASSEMBLY**

- 5.1 Starting with the 1" extension, install the threshold extensions in the order shown (FIG. 1) until the final height is reached. Bring the threshold extensions together at an approximate 45° angle, then rotate them into place after the bulb is engaged in the slot (FIG. 2).
- 5.2 The flap (optional) is inserted in the uppermost threshold extension in the same manner (FIG. 3).
- 5.3 Refer to 'SETUP AND USE' for additional information on usage of the flap.
 - ✎ The flap may not be appropriate in some installations, for instance if its usage would interfere with a sliding door.
- 5.4 Set the assembled ramp in the location where it will be installed.
- 5.5 Drive the #10-24 X 1/2" thread cutting slotted hex washer head screws into the bulb on both sides of each connection (FIG. 4), including the flap if used.
 - ⚠ The screws will keep the extensions aligned but will not keep the extensions from separating if the assembled ramp is lifted off of the ground.

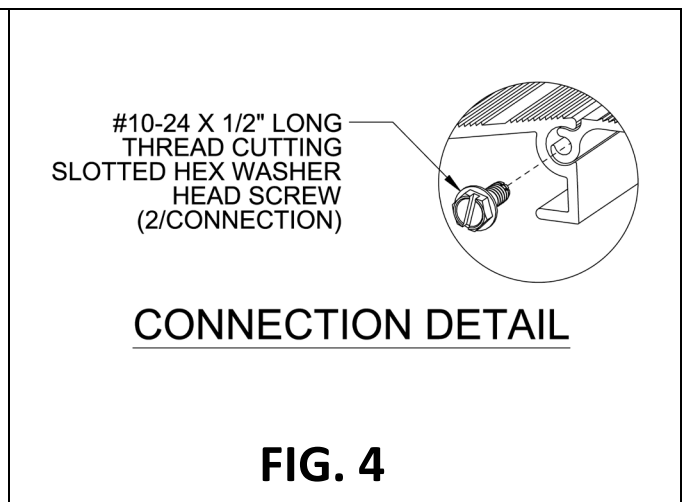
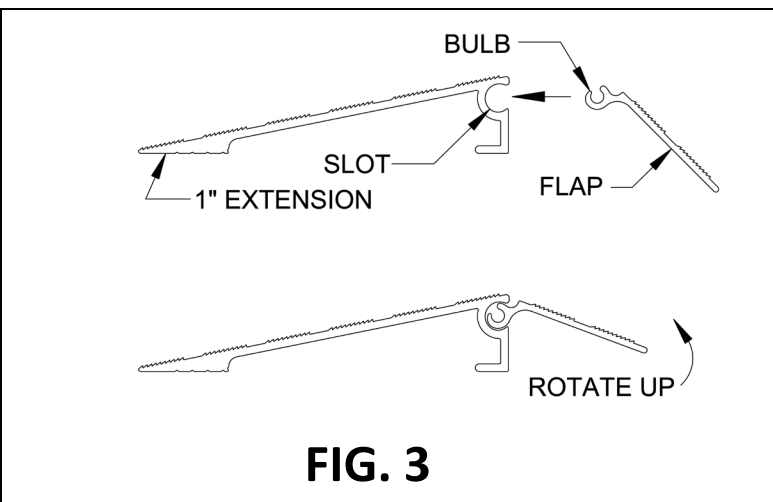
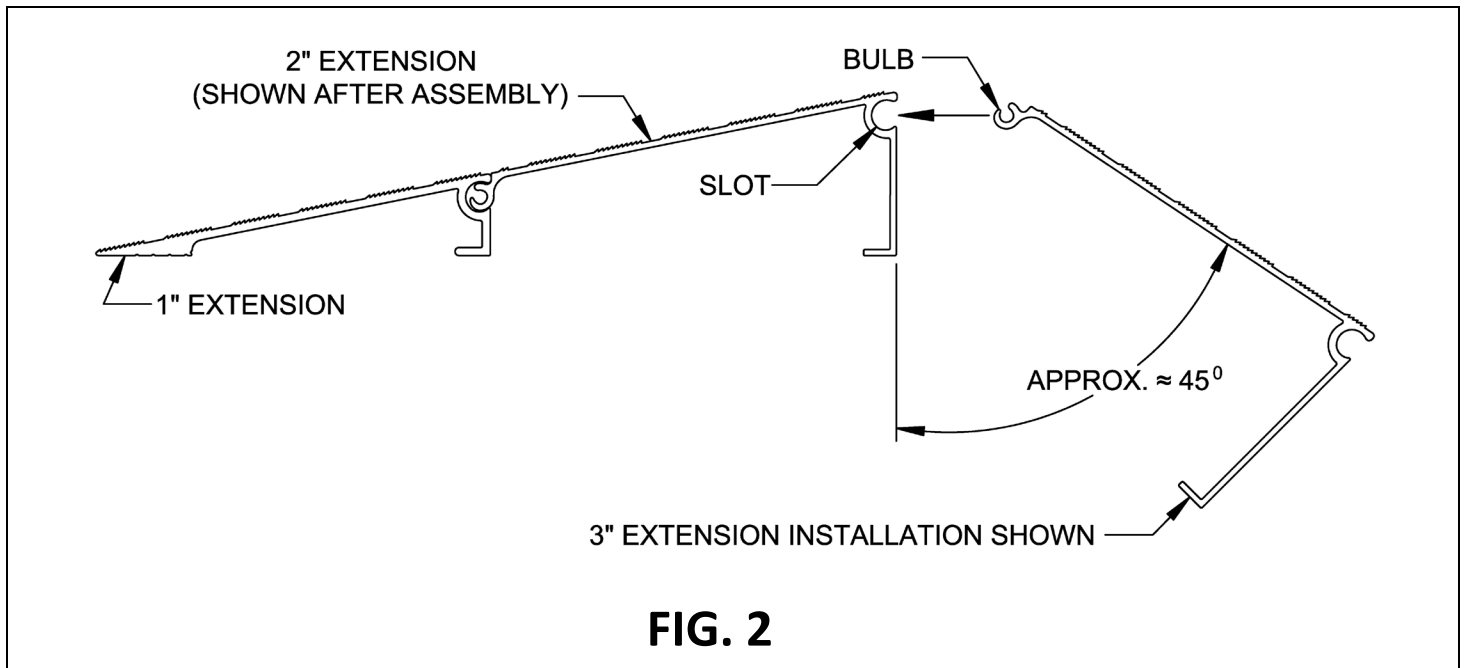

6. SETUP AND USE

- 6.1 If the raised landing is equal to or within a $\frac{1}{4}$ " variance the height of the ramp's top edge (FIG. 5), place the ramp in its intended location and use as is.
 - 6.1.1 Ensure that the location is free of dirt and debris.
- 6.2 Place the ramp flush against the raised landing (FIG. 5).
 - ✎ Regardless of flap use or non-use, no variance of the ramp or flap height, with respect to the landing height, can be greater than $\frac{1}{4}$ " (FIG. 5).
- 6.3 Ensure that the ramp is used on a secure, unobstructed, level landing that is sound enough to safely install anchoring hardware, and that the ramp is flush against the raised landing.
 - ⚠ If a secure, unobstructed, level landing cannot be attained, or if the ramp is not flush against the raised landing, do not use the ramp.
- 6.4 When placing the ramp indoors, foam rubber or other protective material may be used under the ramp to minimize damage to floor surfaces.
 - ⚠ Usage of foam rubber or other protective material may raise the ramp's top edge above the allowed $\frac{1}{4}$ " variance. It is the installer's responsibility to maintain the allowed $\frac{1}{4}$ " variance.
- 6.5 To lift, move, or otherwise handle the ramp after it has been assembled, either disassemble it by reversing the installation procedures, or carefully pick it up from opposing corners (FIG. 6).
 - ⚠ Use a qualified helper to lift, move, or otherwise handle the assembled ramp.

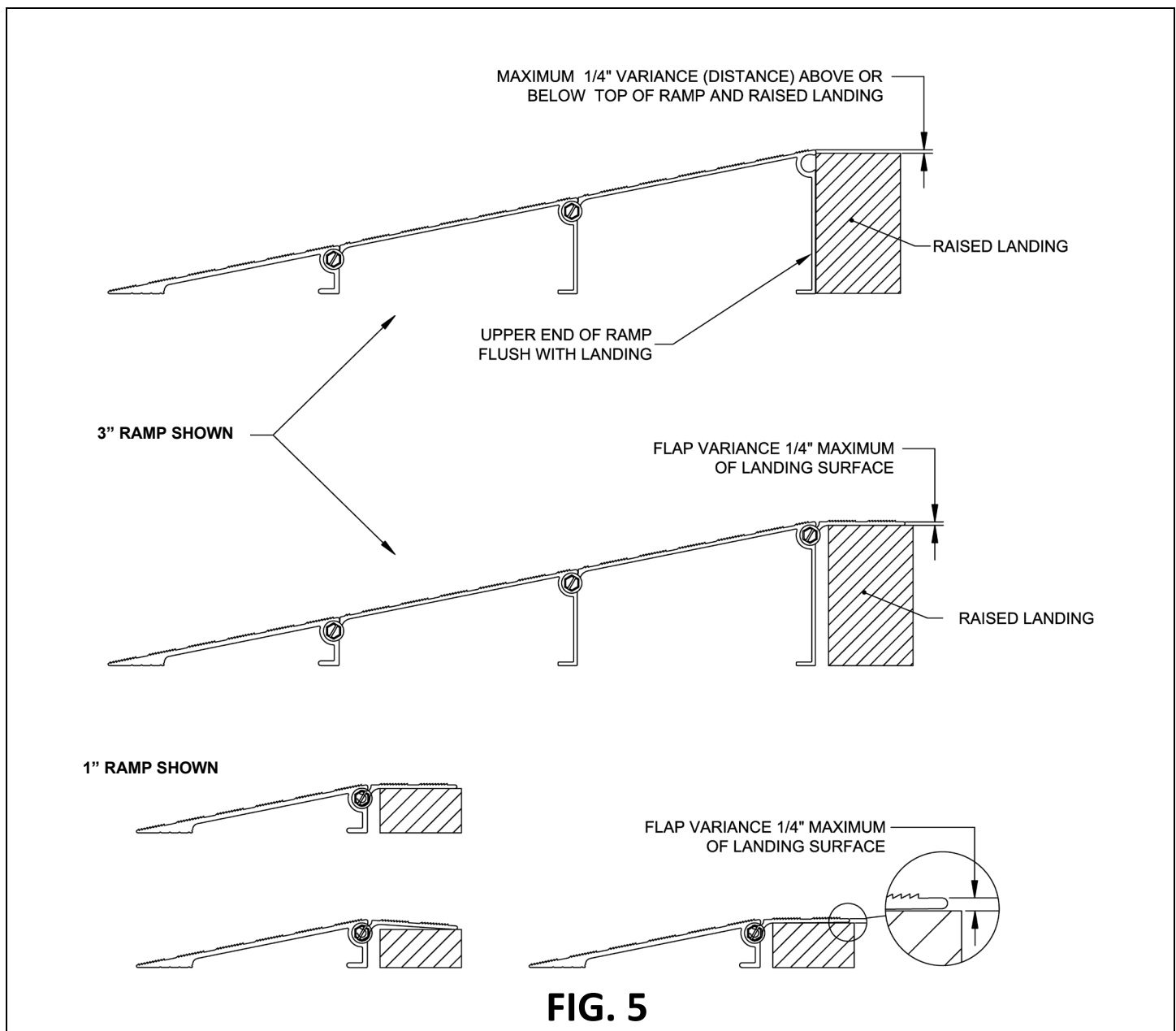
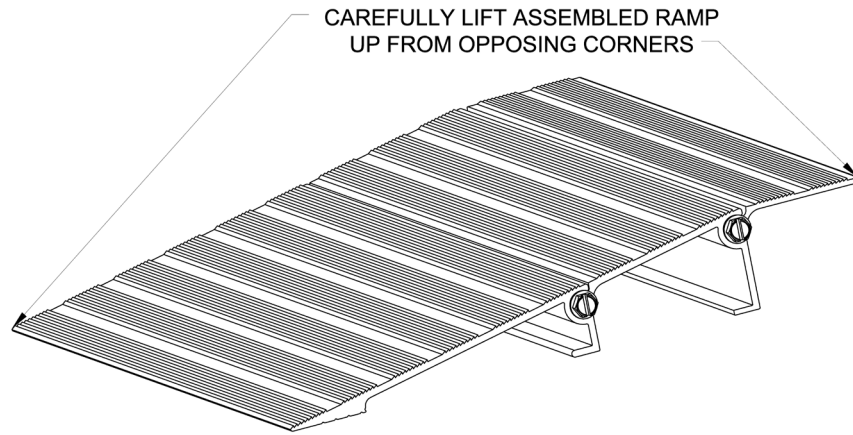

FIG. 5

FIG. 6



7. ANCHOR

7.1 To ensure that the ramp does not move from its intended location, place the ramp and anchor both the foot and the flap or, if the flap is not being used, anchor the foot only in the locations shown (FIG. 7).

⚠ Ensure that the ramp is securely anchored before each use.

7.1.1 ANCHOR TO WOOD OR ALUMINUM: Position the ramp and use the holes in the foot and flap (foot only if the flap is not used) as a template to drill corresponding 1/8" holes into the landing (ensure drilled holes are deep enough to fully seat each screw). Fully insert the provided 1/4" X 1" Long Self Drilling, Self Tapping Pan Head Phillips Screws through the pre-drilled holes and into the corresponding drilled holes in the landing (FIG. 7).

7.1.2 ANCHOR TO CONCRETE: Position the ramp and use the holes in the foot and flap (foot only if the flap is not used) as a template to identify anchor locations. Install non-provided anchoring hardware flush with ramp's surface (FIG. 7) and ensure that it does not create a hazard. It is the installer's responsibility to provide the appropriate 1/2" anchors for the type and thickness of the concrete slab and install them per the manufacturer's instructions.

👉 Concrete anchoring hardware is not provided.

⚠ When using non-provided anchoring hardware, follow hardware manufacturer's installation instructions. Ensure the hardware is of sufficient type and size to prevent ramp slippage or undo movement.

FIG. 7

