

# INSTALLATION AND OPERATION MANUAL

## TRITON 6M Traction table



**Manufactured for DJO**

**For service & repair:**

For US product support please call 1-800-494-3395,  
or visit [djoglobal.com](http://djoglobal.com).

For international product support please contact your  
local dealer, or your corresponding DJO Global site.

---

## CONTENT

1. INTRODUCTION	3
2. FEATURES OF TRITON 6M TRACTION TABLE	3
2.1. INTENDED USE	3
2.2. CE MARK	4
2.3. SYMBOL DEFINITIONS	4
2.4. TECHNICAL DATA	5
3. TRACTION TABLE TRITON 6M DESIGN AND FUNCTIONS	6
3.1. TABLE COMPONENTS	6
3.2. EQUIPMENT AND ADDITIONAL ACCESSORIES	7
3.3. TABLE SET	7
3.4. TRANSPORT AND STORAGE	7
4. GENERAL WARNINGS AND CAUTIONS	8
5. PREPARING THE UNIT FOR USE	9
6. OPERATING THE TABLE	10
6.1. HEIGHT ADJUSTMENT – RAISING (LOWERING) THE BED	10
6.2. ADJUSTING TABLE SECTIONS	11
6.3. POSITIONING THE SLIDING TOP SECTION	12
6.4. ATTACHING AND REPLACING TRACTION UNIT STAND TO TABLE	12
6.5. ASSEMBLY OF TRACTION BELT	13
6.6. PLACEMENT OF TRACTION UNIT	14
6.7. MOVING THE TABLE	14
6.8. ACCESS LOCK	15
7. MAINTENANCE	16
7.1. CLEANING THE UPHOLSTERY	16
7.2. MAINTENANCE OF THE MECHANICAL PARTS	17
7.3. CHECKING THE GAS SPRINGS	17
7.4. CHECKING THE ACTUATOR	17
7.5. PERIODIC CHECK OF ELECTRICAL SAFETY	17
8. TROUBLESHOOTING	18
9. EMC GUIDANCE AND MANUFACTURER'S DECLARATION	19
10. WARRANTY CARD	22

# 1. INTRODUCTION

Congratulations on a perfect choice of our traction table. TRITON 6M is stable, reliable and easy to use. These features result from careful design, manufacturing methods applied in production and the quality assurance system. Reading and following instructions provided in this manual will ensure safe and long lasting use of our table.

## GENERAL INSTRUCTIONS:

1. This product must be operated by personnel who have thoroughly read and understood all the precautionary and operating instructions contained in this operation manual.
2. Using, operating or servicing of the product contrary to the rules and recommendations contained in this user manual is prohibited, as it may lead to damage for which the manufacturer shall not be liable.
3. If the performance or parameters of the product are found to be inconsistent with those described in the operation manual or any damage is noted, you must stop using the product and inform either your local DJO office or authorized dealer immediately.
4. Repair of the product must be done by the local DJO office or authorized dealer and registered on the repair list in the warranty card. Failure to do so will void the warranty.
5. Technical description of the table with a list of spare parts and how to replace them is available from the manufacturer on request.

This warranty will not be fulfilled if the product is used contrary to its purpose or fails to comply with the terms set in the user manual. The manufacturer shall not be liable for the consequences of improper (i.e. against the instructions contained in this user manual) use of the accessories for the traction table.

# 2. FEATURES OF TRITON 6M TRACTION TABLE

This manual describes the features of the TRITON 6M table, not all of the information and drawings contained in it may apply to your table. The manufacturer reserves the right to make changes, not depicted in the current version of the manual, which will not cause degradation of functional and safety conditions of the product.

## 2.1. Intended Use













TRITON 6M traction table is designed to treat the spine under traction together with the traction unit. Traction treatments are performed in order to increase spinal mobility and decompression by relaxing tense muscles and increasing intervertebral disc spacing and foraminal encroachment, which leads to a reduction of oppression and irritation of the nerve roots and improvement of circulation in the area of the vertebral artery.

## 2.2. CE mark



TRITON 6M Traction table with accessories is manufactured in accordance with the essential requirements for medical devices (Class I, rule 12) and carry a CE mark, according to the manufacturer's declaration.

## 2.3. Symbol Definitions

	<p style="text-align: center;"><b>CAUTION !</b></p> <p>This sign denotes operations which - when performed in a way other than described in this manual – may cause injury to the user or damage to equipment.</p>
	<p>Refer to Instruction Manual/Booklet.</p>
	<p>Type B Equipment.</p>
	<p>Manufacturer.</p>
	<p>All electrical and electronic equipment waste must be disposed-of properly at recycling facilities according to the European Union's WEEE directive or equivalent regulations. It is absolutely necessary that all devices which contain substances harmful to the environment or humans are recycled properly in relevant facilities and must not be disposed of with general or household waste. Such regulations ensure that the quantity of electronic waste is reduced and a required amount of electronic devices is recycled properly. Proper recycling of electronic waste is important as it may contain substances harmful to the environment and humans.</p>
	<p>Safe working load.</p>
<p>PELVIC SECTION ADJUSTMENT LOWER</p> 	<p>Pelvic section angle adjustment - lowering</p>
<p>PELVIC SECTION ADJUSTMENT RAISE</p> 	<p>Pelvic section angle adjustment - raising</p>
	<p>Lock/Unlock moveable bed section.</p>
	<p>Head and Chest adjustment control lever</p>
	<p>Arm section adjustment lever</p>
	<p>Graduation range of the pelvic section</p>

## 2.4. Technical data

Table 1 shows the technical characteristics of the TRITON 6M traction table:

Technical data		TRITON 6M	
Table length	arms, chest and head section	72 cm (28,3 in)	
	mid section	22 cm (8,7 in)	
	pelvic section	26 cm (10,2 in)	
	leg section	77 cm (30,3 in)	
	total	217 cm (leg section extended) (85,4 in)	
Angle adjustment / declination / inclination [degrees]	arms, chest and head section	from -30 to 40	
Angle adjustment inclination [degrees]	pelvic section	from 0 to 20	
Angle adjustment inclination [degrees]	leg section	from 0 to 45	
Displacement adjustment	leg section	10 cm (3,9 in)	
Height adjustment	min.	48 ±1 cm (18,9±0,4 in)	
	max.	95 ±1 cm (37,4±0,4 in)	
Table width	all sections	70 cm (27,5 in)	
Duty cycle		discontinuous, short term load (10%) max. 2 minutes "on", min. 18 minutes "off"	
Lifting capacity		≤ 200 kg (440 lbs) (max safe load while adjusting height)	
Working capacity		≤ 275 kg (606 lbs) (max safe load while not adjusting height)	
Weight	Not more than	≤ 165 kg (363 lbs)	
Power and security requirements	Voltage frequency, current consumption	100-240 V; 50/60 Hz; 3,9 A	
	Protection class	I	
	Applied part	type B,	
Protection level	Enclosure control box)	IPX4	
Environment conditions (temperature, relative humidity, air pressure)	work	+10°C to +40°C, from 30% to 75% non-condensing, 700-1060 hPa	
	storage	+5°C to +45°C, not exceeding 75% non-condensing, 700-1060 hPa	
	transport	-10°C to +45°C, from 20% to 95% non-condensing, 700-1060 hPa	

**Table 1 - Technical data**

## 3. TRACTION TABLE TRITON 6M DESIGN AND FUNCTIONS

### 3.1. Table components



#### CAUTION !

It is forbidden to modify tables without written authorization from the manufacturer.

#### CAUTION !



The manufacturer has made every effort to ensure that the product may be used with other traction accessories on the market. At the same time in order to ensure full compatibility and comfort in use, it is recommended to use QuickWrap™ DTS traction belts and mechanical traction unit TRU-TRAC/TRITON of Chattanooga Group, recommended by Meden-Inmed.

The frame of the table is made of welded steel sections coated with powder paint. It includes the following components:

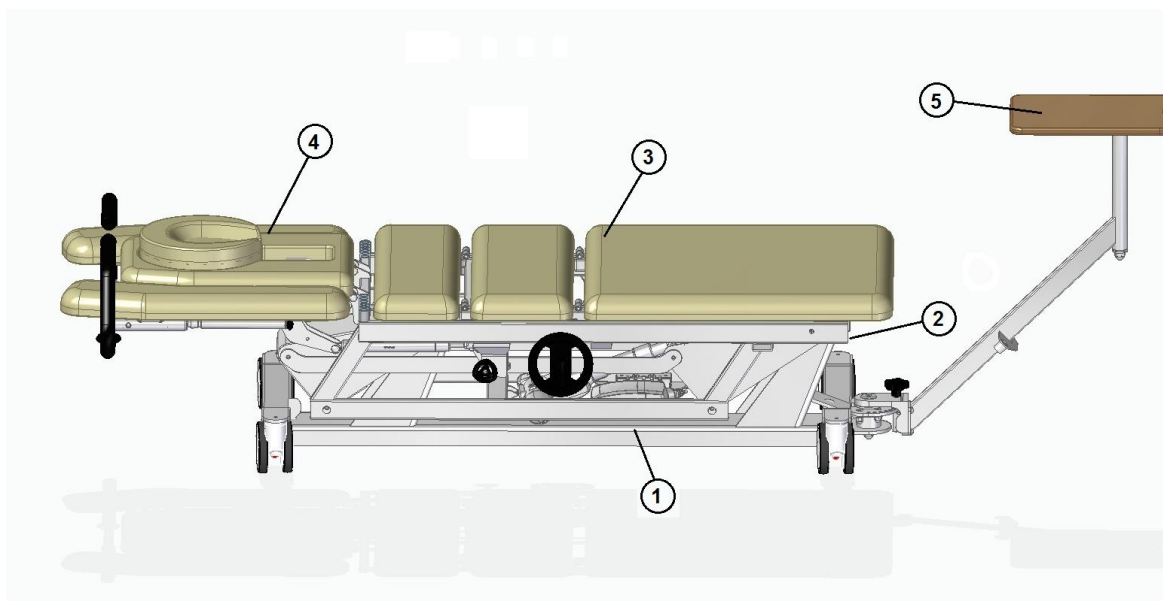

**Picture 1 - Elements of the TRITON 6M Traction table**

- |   |                           |   |
|---|---------------------------|---|
| ① | <b>base frame</b>         | the table support base, equipped with LED, feet and four retractable wheels;  |
| ② | <b>upper frame</b>        | the base for the table top with locking system for the movable parts;   |
| ③ | <b>patient table</b>      | allows patients to assume comfortable position for traction treatment with the possibility of manually adjusting inclination and declination angles of the arms, chest, head and adjusting position of the movable leg section. In addition, the sections: middle, pelvic and leg are equipped with a heating option; |
| ④ | <b>front section</b>      | with angle adjustment, a breathing hole, and a mounting point for the belt;   |
| ⑤ | <b>traction unit base</b> | the base for the traction unit.   |

## 3.2. Equipment and additional accessories



### CAUTION !

Use only accessories recommended or provided by the manufacturer.

Every TRITON 6M traction table is provided with a breathing slot and reinforced mounting point for the traction belt in its front section.

Additionally, the tables may be equipped with the following accessories:

- traction unit TRU-TRAC/TRITON (recommended by Meden-Inmed);
- set of professional traction belts QuickWrap DTS (recommended by Meden-Inmed);
- stabilization belts;
- wedges: 30x40x12 cm and 50x35x20 cm;
- rolls and semi-rolls 60x15 cm and 60x15x10 cm;
- traction supports;
- flexion stool.

## 3.3. Table set

TRITON 6M Traction table	model as per order specs
Installation and operation manual	1 pc.
Additional accessories	as per order specs

## 3.4. Transport and storage

Transport and storage conditions are described in Table 1. The TRITON 6M tables are transported to the customer in a cardboard box on a wooden pallet. Stacking is permitted up to 3 layers using special stackable pallets. External edges of the upholstered parts are protected with foam, bubble wrap and stretch foil. Protect the outer edges of TRITON 6M traction tables against damage while moving or transporting them.

## 4. GENERAL WARNINGS AND CAUTIONS



### CAUTION !

To avoid the risk of electric shock, the device must be connected to a protective earth ground. Do not use any extension cords and splitters.



### CAUTION !

Do not use a table with a power cord other than provided by the manufacturer.



### CAUTION !

Do not allow liquids (coffee, tea, water, detergents and disinfectants) to contact the actuator electrical wiring and other components of the table. In the case of water damage to electrical wiring or actuator conduit the table should be immediately disconnected from the power supply by removing the plug from the outlet. It is recommended to have the table examined by a qualified technician.



### CAUTION !

TRITON 6M traction table has a limited load capacity! The safe working load should not exceed 200 kg (440 lbs) when lifting and the total load should not exceed 275 kg (606 lbs).



### CAUTION !

If the patient is placed in the wrong position relative to the moving parts of the bed, there is a risk of injury to the body or table structure.

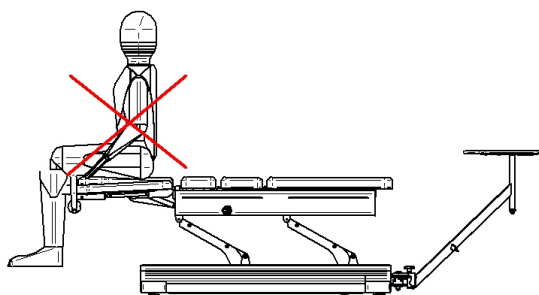

**INCORRECT**

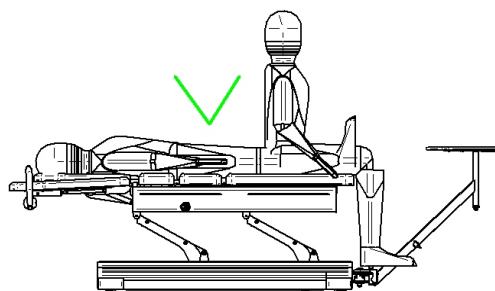

**CORRECT**

***Picture 2 - Correct and incorrect loading of the table***

Help the patient to maintain proper position before treatment by lowering the table to the lowest position. Likewise, lower the table after the treatment to help the patient to get off the table. The manufacturer is not liable for the consequences of improper (not in accordance with the conditions set out in this manual) use of the TRITON 6M traction tables.



## 5. PREPARING THE UNIT FOR USE

### CAUTION !



When setting or changing the place of use of the TRITON 6M traction table, ensure that there are no objects in the space below the bottom frame of the table. Do not allow access to children or animals. Do not place objects in the space under the table to avoid damage during movement.

### CAUTION !



In order to safely disconnect the power supply system of the table, unplug the power cord from the socket.

### CAUTION !



Unplug the table from the mains socket while performing maintenance, servicing or similar actions under the table.

### CAUTION !



When connecting the electrical power supply cable, make sure to protect it from accidental clamping of objects between moving parts of the table. The electrical power supply cable should be laid in such a manner so as to prevent the patient or the user from tripping over it.

### CAUTION !



Do not use the table in rooms with high relative air humidity (especially in rooms meant for hydro-therapeutic treatment).

Before use, ensure that there is a minimum clearance of 80 cm (31,5 in) on each side of the table.

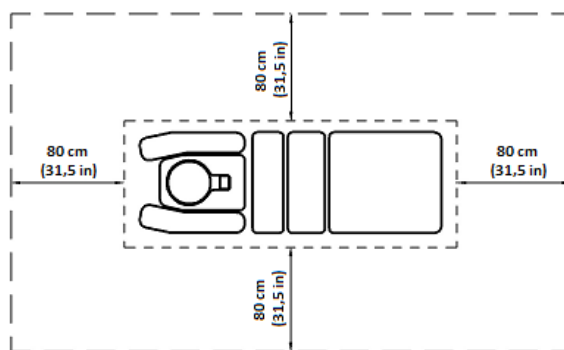

**Picture 3 - Recommended positioning of the TRITON 6M Traction table**

Once the table is in position, unpack it from the transport foil and plug the power cord into the mains socket, ensure it is freely accessible when using the table.

## 6. OPERATING THE TABLE



### CAUTION !

Always maintain a safe distance from the table mechanisms operating at the time of adjusting the height and position of the section table. Moving parts pose a risk.



### CAUTION !

When using other electrical appliances near the table, make sure that their power cables are not clamped or damaged by moving parts of the table.



### CAUTION !

Before starting work on the table, make sure that the wheels are locked. (pic. 4).



### CAUTION !

Before starting work, user should make sure that the patient is in a safe position.



### CAUTION !

Avoid contact of upholstered surfaces with: oils, lotions, cosmetics. Contact with such agents can cause stiffening and cracking of the cover material, as well as a change in gloss of the upholstery surface, not covered by the warranty.

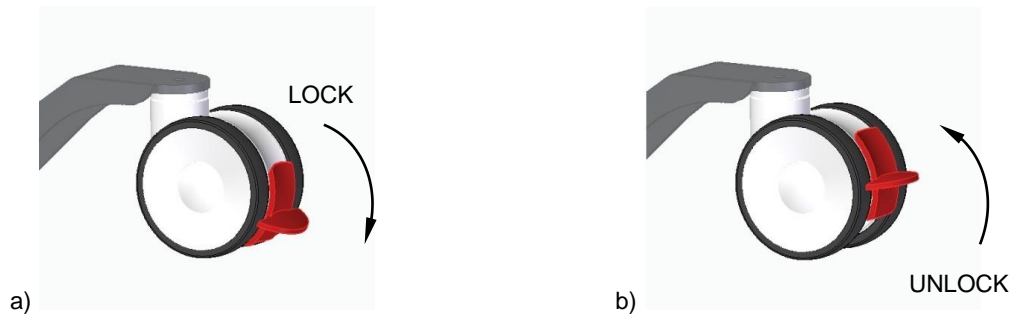

Picture 4 – Locking TRITON 6M wheels a) LOCK b) UNLOCK

Prepare a disposable bed cover (such as paper towels, disposable sheets etc.) for each patient before using the TRITON 6M traction table for treatment procedures. The patient should wear comfortable clothing, which will help relax the patient and ensure effective treatment.

### 6.1. Height adjustment – raising (lowering) the bed



### CAUTION !

Before starting work the user should make sure that the patient is in a safe position.

The height of the Triton 6M table is adjusted using the hand remote and foot control. To raise the table to the desired height, press **↑** on the foot control or the **+** on the remote control. To lower the table, press the **▬** on the foot control or the **↓** on the remote control (pic.5). Lifting (lowering) the table continues as long as the foot or hand button is depressed. When the maximum or minimum height is reached, the actuator is automatically deactivated.



a) remote control



b) foot control

**Picture 5— Height adjustment a) remote control b) foot control**

## 6.2. Adjusting Table Sections



### CAUTION !

Before adjusting the table, the user should make sure that the patient is in a safe position.



### CAUTION !

Do not insert your fingers into the gaps between the segments of the table, as this could trap them when lifting or regulating and the position of the table.

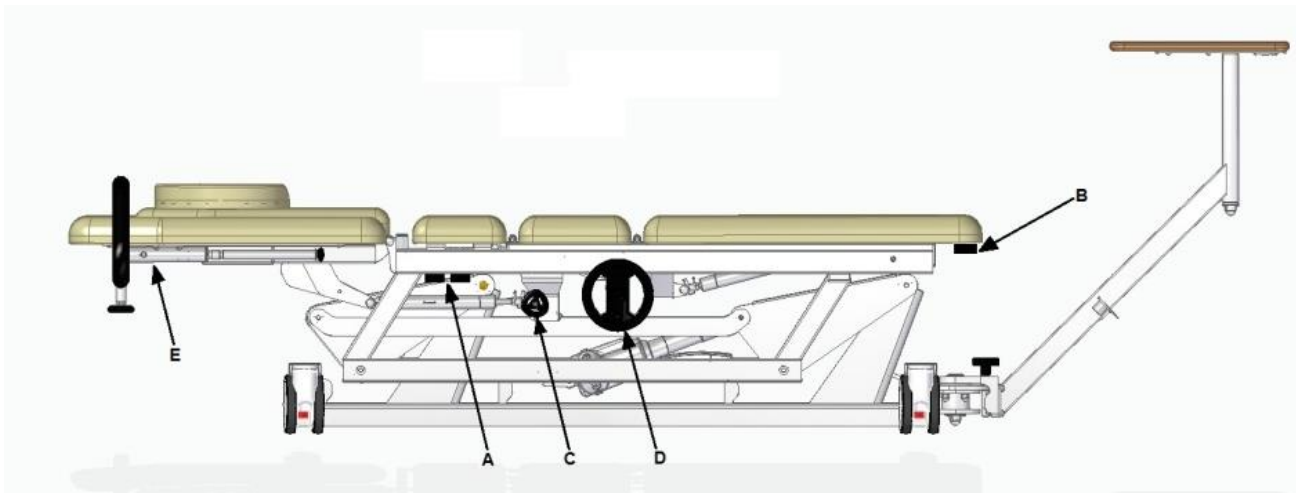

**Picture 6 - Regulation elements of TRITON 6M Traction table**

In order to adjust the tilt of the TRITON 6M front section, release the gas spring lock by holding down the lever (pic. 6 - position A), set the desired position of the front section, and lock in place releasing the lever. To tilt the back of the TRITON 6M table, release the gas spring lock by holding down the lever (pic. 6 - position B), set the desired leg section position, and lock in place by releasing the lever. To adjust the tilt of the TRITON 6M pelvic section, release the rotary knob handle and set the desired value for the tilt angle of the pelvic (pic. 6 - D position).

### 6.3. Positioning the sliding top section

#### CAUTION !



Before adjusting the table, make sure the patient is in a safe position.

#### CAUTION !



Do not insert your fingers into the gaps between the segments of the table, as this could trap them when lifting or regulating and the position of the table.

It is possible to extend the pelvic section of the Triton 6M table. Locate the lock release knob, located on the left and right side of the top frame (pic. 7) to operate this function. To unlock and move the sliding section, turn the knob to UNLOCK (it cannot be unscrewed fully). Slide the section to the desired position and turn the knob to LOCK (pic. 7) to fix the cushion in place.

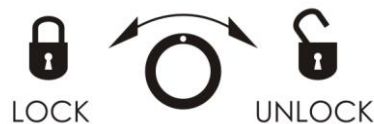

*Picture 7 - Lock release knob for sliding section of table.*

### 6.4. Attaching and replacing traction unit stand to table

#### CAUTION !



The TRITON 6M traction table is transported to the customer with the traction unit bracket removed.

In order to mount (remove) the traction unit bracket to the swivel arm in the bottom frame (pic. 8), use the screws (ISO 7380 M8×25 - 4 pcs), spring washers (DIN 7980 ø 8,1 - 4 pcs.) and a hexagonal Allen key (No 5).

The traction unit base in the TRITON 6M traction tables has a rotation of ± 90 degrees, as well as a step blockade every ~13 degrees. In order to unlock the unit base stand, unscrew the safety lock (pic.8 - A) - the safety knob cannot be unscrewed fully, set the working degree of the traction unit and tighten the safety knob to lock in place.



*Picture 8 - Attaching and replacing the traction unit base arm of the TRITON 6M traction table.*

To secure the traction unit to the stand, loosen the clamp from the traction unit. Fit the unit to the stand and tighten the clamp. In addition, the traction unit can be secured onto the traction unit base (pic. 9) by tightening the mounting screw (2) into the hole (1). The mounting screw is supplied with the traction unit only.

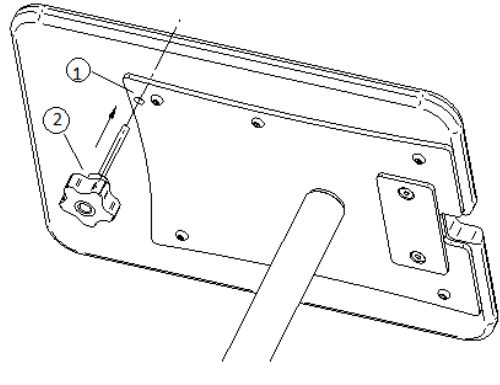

**Picture 9. –Mounting the traction unit**

## 6.5. Assembly of traction belt



### CAUTION !

During the use of the traction belt, refer to the User Manual enclosed by the belt manufacturer.

The traction belt is fixed using the designated hook. It is placed in the headrest hinge plate (pic. 10 - A). Before attaching the traction belt, remove the upholstered cap which is attached magnetically. Then the traction belt hook can be attached.

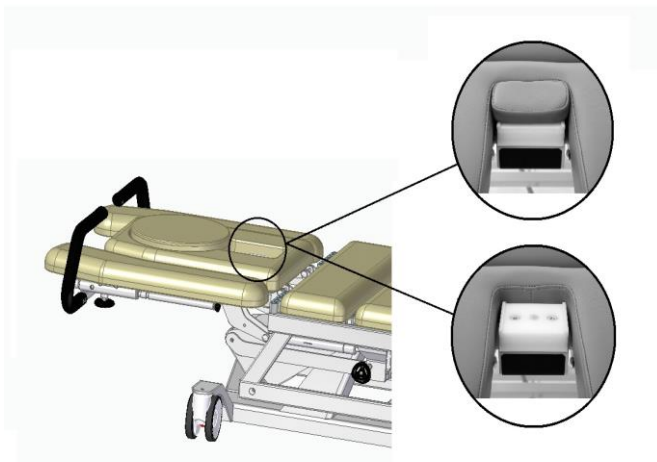

Upholstered cap mounted - work on the table without the traction belt attached.

Upholstered cap removed - work on the table with the traction belt attached.

**Picture 10 - Location for the traction belt hook**

## 6.6. Placement of traction unit



### CAUTION !

Triton Traction/Tru-Trac Unit - the mechanical spine traction device is put on a 360°-rotating plate. The traction unit must be placed on the plate facing the direction of pull and table.



### CAUTION !

To set, lock and use the traction unit, the user needs to follow instructions in the User Manual supplied.

Mounted mechanical spine traction device Triton Traction/Tru-Trac Unit on the swivel base is shown in the picture 11



*Picture 11 – Assembly of traction unit*

## 6.7. Moving the table



### CAUTION !

Before changing the location of the table, make sure that the mains plug of the power cord is removed from the AC outlet and protected against accidental damage during relocation.



### CAUTION !

It is forbidden to move the TRITON 6M Traction table with a patient on the table.



### CAUTION !

Any manipulation of the position change lever WORK-TRANSPORT should be performed with the table without the patient.

TRITON 6M is equipped with four wheels with total lock.

- WORK - during work the table rests on wheels with total lock on;
- TRANSPORT - the table rests on the wheels with total lock off.

## 6.8. Access lock



### CAUTION !

When not in use, always shut down the table and ensure that it cannot be used by unauthorized persons. To check it is locked, press any button on the remote or foot control.

The TRITON 6M is equipped with an access lock mechanism for the height adjustment function. There are two steps of locking access to the height adjustment function

To lock the height adjustment function simultaneously press the button on the remote control **↑** and the footswitch **+** (pic. 12 - 1<sup>st</sup> step). Confirmation of the lock is signaled by a short beep. Next, insert the key **①** into the remote control slot **②** and turn right to the symbol marked **🔒** (pic. 13 - 2<sup>nd</sup> step).

When access to the height adjustment function is blocked, each press of the buttons on the remote control or foot is signaled by a beep.

To unlock the access lock, insert the key **①** into the lock slot on the remote control **②** and turn to the symbol marked **🔓** and simultaneously press the button **↓** on the remote control and the footswitch minus **-**. The locking confirmation is indicated by a double short beep.



Picture 12 - Access lock mechanism



Picture 13 - Access lock mechanism with the key

## 7. MAINTENANCE



### CAUTION !

We recommend cleaning and/or disinfecting the upholstered surfaces and other parts of the tables after each use to ensure proper hygiene.



### CAUTION !

Before cleaning the table, ensure that the electrical power supply cable has been disconnected from the mains to prevent accidental movement of the table.



### CAUTION !

Estimated lifetime of the device is 7 years. After 7 years from the date of table manufacture, (and its equipment), the manufacturer is not held accountable for any flaws of the device (and its equipment), as well as their consequences.

### 7.1. Cleaning the upholstery

Clean and maintain the upholstered surfaces as follows:

- clean regularly with warm water and mild detergent (e.g. soap) solution; use soft cloth or sponge;
- rub the more heavily stained areas with a soft, damp brush;
- after cleaning, wipe dry with a soft cloth;
- in case the surface has been stained with ball pen ink, lipstick, ink etc., remove the stain immediately by rubbing it with a soft cloth.

Avoid extensive wetting of the surface of the table.

Disinfect the upholstery and other surfaces using the mild antibacterial detergent. A list of recommended disinfectants is available in the DJO on request.

Never use:

- cleaning paste, wax, sprays;
- strong detergents, solvents and cleaning agents containing solvents, cleaning preparations for natural leather.

Use of such preparations may cause stiffening and breakages of the cover material as well as adverse change of the glossy finish of the upholstery surface which is not covered by the warranty.

Disinfection with the use of the UV rays does not affect the surface of the upholstery.



## 7.2. Maintenance of the mechanical parts

Clean the metal parts with a soft, damp sponge. Wipe the parts dry immediately after cleaning. Do not use cleaning agents containing alcohol.

All movable parts must be lubricated every six months or when experiencing squeaks or other noise.

These joints include in particular:

- axles of transport wheels,
- actuator mounting shafts,
- boom arm sleeve bearing.
- mechanism of sliding section of movable part of the bed.

We recommend using any available retail lubricants. Protect the upholstered parts from contact with the lubricants and remove any excess with a dry cloth.

Check the threaded joints periodically every six months and tighten loose connections with a screwdriver, hex keys (no 4, 5, 6) and flat (10, 13 and 19 mm). Especially:

- bolts attaching the boom arms to the lower and upper frame;

Report all loose connections that cannot be tightened to your DJO technical service center and stop using the table until the cause of the problem is resolved.

## 7.3. Checking the gas springs

TRITON 6M Traction tables are equipped with gas springs for easy adjustment of the arms, chest & head and leg section inclination angle. To ensure proper performance of the gas springs check the springs visually for leaks every 3 months. Any perceived performance deficiency or leak must be reported to your local DJO technical service centre immediately.

## 7.4. Checking the actuator

TRITON 6M Traction tables are equipped with electric actuator which changes the height of the table. In order to ensure the proper performance of the electric actuator we recommend a check every 3 months for any unexpected sounds (rattles, squeaks etc). Any perceived performance deficiency must be reported to your local DJO technical service centre immediately and stop using the table until the cause of the problem is removed.

## 7.5. Periodic check of electrical safety

Not less frequently than once a year and each time after a failure/repair, the technical services of the user must inspect a table or commission such an inspection with regard to electrical safety of its use. Electrical safety measurements should be made in accordance with PN-EN 62353.

The minimum scope of the inspection should include:

- checking if there is any mechanical damage to the wiring;
- checking if there is any mechanical damage to electrical components;
- measurement of resistance of the grounding path;
- measurement of leakage current of the device.

Measurement of resistance of grounding path should be made from the point indicated in Fig. 14.

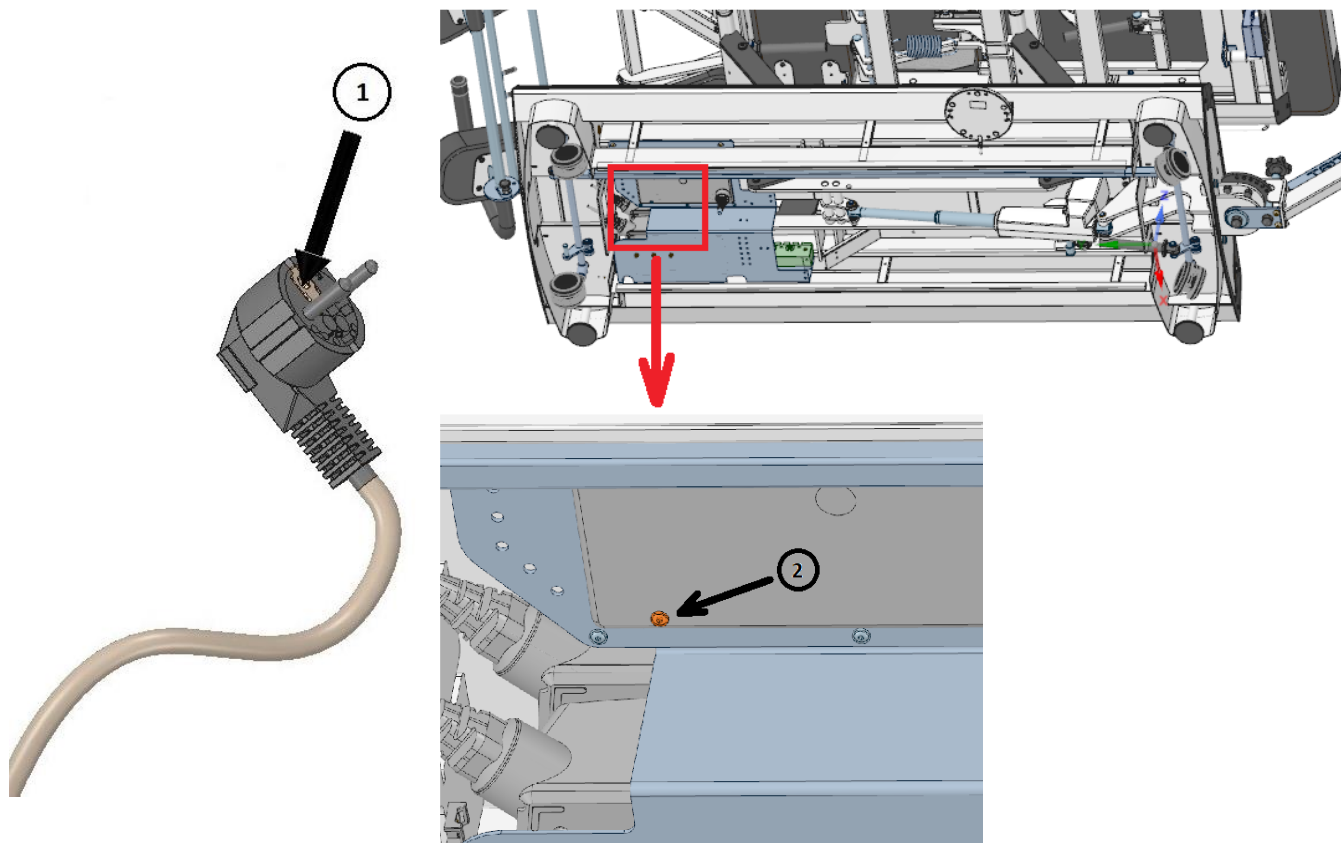

- ① protection ground contact of outlet plug
- ② test point

**Picture 14 - Measuring point of protective earth resistance**

## 8. TROUBLESHOOTING

Failure indication	Possible cause	Action to be taken
The height adjustment mechanism does not work	Exceeded the continuous work cycle	If necessary, remove the patient from the table, with help if required. Remove the mains plug from the electrical socket and wait a minimum of 1 hour. Then re-connect the table to the mains socket.
	Disconnected power cord	Check if the power cord is plugged into the power supply socket of the controller and the AC outlet.
	Height adjustment access lock is activated	Unlock the access lock to height adjustment.
Control mechanism interrupts operation	Exceeded safe working load	Reduce the load on the table.

If the fault persists, stop using the table, unplug the power cord, remove the lock and contact the supplier or the manufacturer.

## 9. EMC guidance and manufacturer's declaration

Essential Performance - there are no essential performance characteristics according to the risk assessment of the equipment\* *Traction table TRITON 6M*.

<b>Guidance and manufacturer's declaration – electromagnetic emissions</b>		
The equipment* is intended for use in the electromagnetic environment specified below. The customer or the user of the equipment* should assure that it is used in such an environment.		
<b>Emissions test</b>	<b>Compliance</b>	<b>Electromagnetic environment – guidance</b>
RF emissions CISPR 11	Group 1	The equipment* uses RF energy only for its internal function. Therefore, its RF emissions are very low and are not likely to cause any interference in nearby electronic equipment.
RF emissions CISPR 11	Class A	The equipment* is suitable for use in all establishments other than domestic and those directly connected to the public low-voltage power supply network that supplies buildings used for domestic purposes.
Harmonic emissions IEC 61000-3-2	Class A	
Voltage fluctuations/ flicker emissions IEC 61000-3-3	Complies	

WARNING: Use of this equipment adjacent to or stacked with other equipment should be avoided because it could result in improper operation. If such use is necessary, this equipment and the other equipment should be observed to verify that they are operating normally.

WARNING: Use of accessories, transducers and cables other than those specified or provided by the manufacturer of this equipment could result in increased electromagnetic emissions or decreased electromagnetic immunity of this equipment and result in improper operation.

WARNING: The EMISSIONS characteristics of this equipment make it suitable for use in industrial areas and hospitals (CISPR 11 class A). If it is used in a residential environment (for which CISPR 11 class B is normally required) this equipment might not offer adequate protection to radio-frequency communication services. The user might need to take mitigation measures, such as relocating or re-orienting the equipment.

WARNING: Device may be susceptible to electromagnetic disturbances, but Basic Safety and Essential Performance are maintained.

<b>Guidance and manufacturer's declaration – electromagnetic immunity</b>			
The equipment* is intended for use in the electromagnetic environment specified below. The customer or the user of the equipment* should assure that it is used in such an environment.			
<b>IMMUNITY test</b>	<b>IEC 60601 test level</b>	<b>Compliance level</b>	<b>Electromagnetic environment – guidance</b>
Electrostatic discharge (ESD) IEC 61000-4-2	± 8 kV (contact) ± 2/4/8/15 kV (air)	± 8 kV (contact) ± 2/4/8/15 kV (air)	Floors should be wood, concrete or ceramic tile. If floors are covered with synthetic material, the relative humidity should be at least 30 %.
Electrical fast transient/burst IEC 61000-4-4	±2 kV for power supply lines 100 kHz	±2 kV for power supply lines 100 kHz	Mains power quality should be that of a typical commercial or hospital environment.

Surge IEC 61000-4-5	± 1 kV line(s) to line(s) ± 2 kV line(s) to earth	± 1 kV line(s) to line(s) ± 2 kV line(s) to earth	Mains power quality should be that of a typical commercial or hospital environment.
Voltage dips, short interruptions and voltage variations on power supply input lines IEC 61000-4-11	0 % U <sub>T</sub> ; 0,5 cycle at 0°, 45°, 90°, 135°, 180°, 225°, 270° and 315°  0 % U <sub>T</sub> ; 1 cycle and 70 % U <sub>T</sub> ; 25/30 cycles (50/60Hz) 1 phase: at 0°  0 % U <sub>T</sub> ; 250/300 cycles (50/60Hz)	0 % U <sub>T</sub> ; 0,5 cycle at 0°, 45°, 90°, 135°, 180°, 225°, 270° and 315°  0 % U <sub>T</sub> ; 1 cycle and 70 % U <sub>T</sub> ; 25/30 cycles (50/60Hz) 1 phase: at 0°  0 % U <sub>T</sub> ; 250/300 cycles (50/60Hz)	Mains power quality should be that of a typical commercial or hospital environment. If the user of the equipment* requires continued operation during power mains interruptions, it is recommended that the equipment* be powered from an uninterruptible power supply or a battery.
Power frequency (50/60 Hz) magnetic field IEC 61000-4-8	30 A/m	30 A/m	Power frequency magnetic fields should be at levels characteristic of a typical location in a typical commercial or hospital environment.
NOTE U <sub>T</sub> is the a.c. mains voltage prior to application of the test level.			

#### Guidance and manufacturer's declaration – electromagnetic immunity

The equipment\* is intended for use in the electromagnetic environment specified below. The customer or the user of the equipment\* should assure that it is used in such an environment.

IMMUNITY test	IEC 60601 TEST LEVEL	Compliance level	Electromagnetic environment – guidance
Conducted RF IEC 61000-4-6	3 V 0,15 MHz – 80 MHz 6 V in ISM bands between 0,15 MHz and 80 MHz 80 % AM at 1 kHz	3 V 0,15 MHz – 80 MHz 6 V in ISM bands between 0,15 MHz and 80 MHz 80 % AM at 1 kHz	WARNING: Portable RF communications equipment (including peripherals such as antenna cables and external antennas) should be used no closer than 30 cm (12 inches) to any part of the equipment*, including cables specified by the manufacturer. Otherwise, degradation of the performance of this equipment could result.  These guidelines may not apply in all situations. Electromagnetic propagation is affected by absorption and reflection from structures, objects and people.
Radiated RF IEC 61000-4-3	3 V/m 80MHz do 2,7GHz	3 V/m 80MHz do 2,7GHz	
Proximity fields from RF wireless communications equipment IEC 61000-4-3	EN 60601-1-2:2015, Table 9 (see below)  <input checked="" type="checkbox"/> Professional healthcare facility environment	Complies  <input checked="" type="checkbox"/> Professional healthcare facility environment	

**Proximity fields from RF wireless communications equipment**

Test frequency (MHz)	Band <sup>a)</sup> (MHz)	Service <sup>a)</sup>	Modulation <sup>b)</sup>	Maximum power (W)	Distance (m)	Immunity test level (V/m)
385	380 – 390	TETRA 400	Pulse modulation <sup>b)</sup> 18 Hz	1,8	0,3	27
450	430 – 470	GMRS 460, FRS 460	FM <sup>c)</sup> ± 5 kHz deviation 1 kHz sine	2	0,3	28
710	704 – 787	LTE Band 13, 17	Pulse modulation <sup>b)</sup> 217 Hz	0,2	0,3	9
745						
780						
810	800 – 960	GSM 800/900, TETRA 800, iDEN 820, CDMA 850, LTE Band 5	Pulse modulation <sup>b)</sup> 18 Hz	2	0,3	28
870						
930						
1720	1700 – 1990	GSM 1800; CDMA 1900; GSM 1900; DECT; LTE Band 1, 3, 4, 25; UMTS	Pulse modulation <sup>b)</sup> 217 Hz	2	0,3	28
1845						
1970						
2450	2400 – 2570	Bluetooth, WLAN 802.11 b/g/n, RFID 2450, LTE Band 7	Pulse modulation <sup>b)</sup> 217 Hz	2	0,3	28
5240	5100 – 5800	WLAN 802.11 a/n	Pulse modulation <sup>b)</sup> 217 Hz	0,2	0,3	9
5500						
5785						

NOTE If necessary to achieve the IMMUNITY TEST LEVEL, the distance between the transmitting antenna and the ME EQUIPMENT or ME SYSTEM may be reduced to 1 m. The 1 m test distance is permitted by IEC 61000-4-3.

<sup>a)</sup> For some services, only the uplink frequencies are included.

<sup>b)</sup> The carrier shall be modulated using a 50 % duty cycle square wave signal.

<sup>c)</sup> As an alternative to FM modulation, 50 % pulse modulation at 18 Hz may be used because while it does not represent actual modulation, it would be worst case.

---



---



---



---



Repairs Registry	User's Notes