

Use



## H Series 105 Gallon Stationary Whirlpool H-105-S



Product photo/image above may show some available options

**H-105 Stationary Whirlpool** is recommended for shallow or deep body immersion offering complete coverage of extremities as well as the entire back and shoulder area with greater patient comfort.

**Tank Capacity** is 105 gallons.

**Whirlpool Tank** is 48"L x 24"W x 28"D and is seamless welded construction, fabricated from heavy gauge, type 304 stainless steel, polished to a satin finish. Tank rim is reinforced with a concealed stainless steel rod. Tank bottom is seamless, rounded coved design to minimize bacteria buildup. Tank is also provided with an extended stainless steel skirt flush to the floor line to conceal internal drain piping.

A 2" Combination Drain and Overflow, and a Filler Spout are provided. (See roughing-in dimensions on the reverse side).

**Turbine Raising and Lowering Device** permits adjustment of desired height and direction of water agitation towards the area of the body to be treated. It is spring balanced and provided with a locking device.

**Turbine Assembly** functions both as agitator and emptying device. It is equipped with Underwriters Laboratory listed 1/2 HP jet pump motor protected with an ABS plastic shell, and automatic thermal

overload protector, and lifetime-sealed bearings. All parts contacting the water are stainless steel, chrome plated brass or bronze.

**Thermometer** is provided with a dual scale, adjustable calibration, and a stem inserts into a retainer to prevent rattle during whirlpool agitation.

### GUIDE SPECIFICATIONS

Provide Stationary Whirlpool (specify model number and options) with a 105-gallon capacity, 48"L x 24"W x 28"D. Whirlpool shall be fabricated from heavy gauge, type 304 stainless steel. Construction shall be seamless welded and exposed surfaces shall be polished to satin finish. Tank shall have a reinforced rim and shall be fitted with a stainless steel skirt flush to the floor line. Bottom of tank shall be a seamless, rounded coved design to minimize bacteria build up. Provide a 2" combination drain and overflow, and a filler spout. Provide a turbine assembly with raising and lowering device which functions both as agitator and emptying device, permits adjustment of desired height, direction of water agitation, and can be locked into place. Turbine assembly shall be UL listed 1/2 HP jet pump motor with automatic thermal overload protector, and lifetime-sealed bearings. Provide a 3" dial thermometer with a stem retainer to prevent rattle when whirlpool is in operation.



Member of  
U.S. Green  
Building Council



Recycleable  
Product

# Hi-Boy Whirlpools

## MODEL NUMBER AND OPTION SELECTIONS

### Series

- H Hi-Boy Series

### Capacity

- 105 Gallons

### Type

- S Stationary Whirlpool

### Suffix Options (See Whirlpool Option Section for Details)

- AHC1 Adjustable High Chair with Casters
- AHC2 Adjustable High Chair with Rubber Tips
- ARS Arm Rest Support
- AS2 Adjustable Suspension Seat
- CTS2 Combination Table with Seats
- EG Enviro Glaze Color Powder Coating - Specify Color: \_\_\_\_\_

(Special Finish Consult Factory)

- GFI Ground Fault Interrupter
- MXT1 Thermostatic Mixing Valve (15 G.P.M.)
- MXT2 Thermostatic Mixing Valve (25 G.P.M.)
- MXWH Washout Hose Attachment for MXT Valves
- PCS Pump Cover Strainer
- PHS2 Patient Handling System (Chair Type)
- RHG Rubber Hand Grips
- SDO Separate Drain and Overflow Assembly
- TTS2 Tank Top Seat
- WLS Water Level Sensor

### Turbine Assembly

Electrical on standard turbine supplied is 115 V 60 Hz  
if 220 V is required please specify:

- 50 Hz
- 60 Hz

All dimension figures in parentheses are in millimeters.

**ELECTRIC REQUIREMENTS:**  
Amps: 8  
Volts: 115  
Hertz: 60  
GFI Receptacle



VALVE	INLETS	OUTLET	DIM A	DIM B	DIM C
MXT1 (15 GPM)	1/2" NPT	1/2" NPT	8-1/2" (215)	13-3/4" (350)	18" (455)
MXT2 (25 GPM)	3/4" NPT	3/4" NPT	9-1/2" (240)	13-1/2" (345)	17" (430)

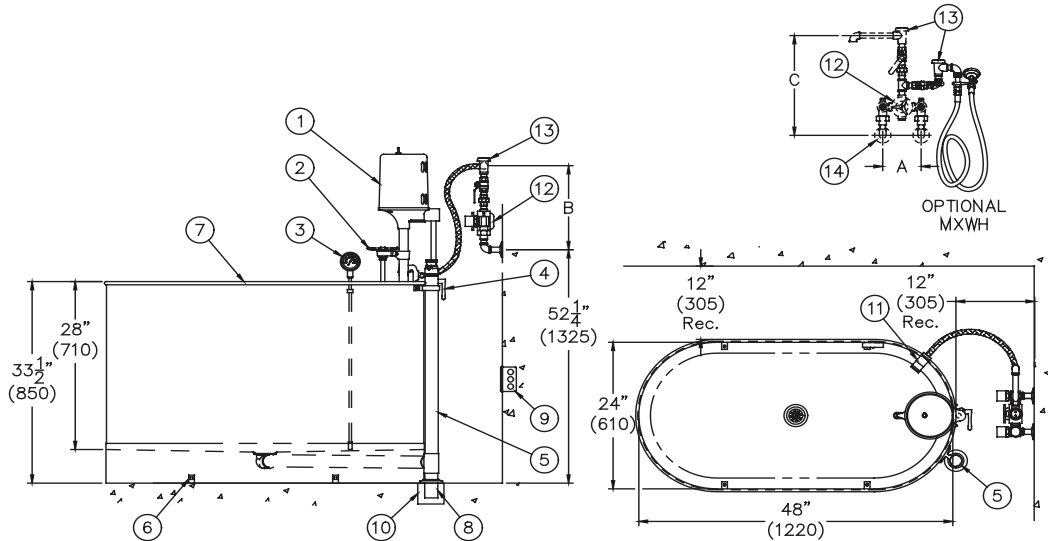

STATIONARY H-105-S SERIES WHIRLPOOL

### NOTES:

- |   |                                     |   |
|---|-------------------------------------|---|
| 1. 1/2 hp Jet Pump Motor.                 | 6. "L" Brackets -Four Each.         | 10. Floor Drain by Others.                            |
| 2. Variable Pressure Control.             | 7. Stainless Steel Tank.            | 11. Filler Spout.                                     |
| 3. Thermometer.                           | 8. 2" O.D. x 5" Tail Piece.         | 12. Optional Thermostatic Mixing Valve. Must Specify. |
| 4. Turbine Raising & Lowering Device.     | 9. 3 Pole GFI Receptacle by Others. | 13. Mixing Valve Vacuum Breaker.                      |
| 5. Combination Drain & Overflow Assembly. |                                     | 14. Mixing Valve Supply Inlets.                       |

### SELECTION SUMMARY & APPROVAL FOR MANUFACTURING

Model Number & Options \_\_\_\_\_ Quantity \_\_\_\_\_

Company \_\_\_\_\_ Date \_\_\_\_\_

Contact \_\_\_\_\_ Title \_\_\_\_\_

Approval for Manufacturing/Signature \_\_\_\_\_