

Lo-Boy Whirlpools



L Series 105 Gallon Mobile Whirlpool

Model L-105-M



Product photo/image above may show some available options

L-105-M Mobile Whirlpool is recommended for treatment of extremities, hip and back area and allows space for exercising.

Tank Capacity is 105 gallons.

Whirlpool Tank is 66"L x 24"W x 18"D and is seamless welded construction, fabricated from heavy gauge, type 304 stainless steel, polished to a satin finish. Tank rim is reinforced with a concealed stainless steel rod. Tank bottom is a seamless, rounded covered design to minimize bacteria buildup.

Heavy Duty Swivel Casters support all mobile models. Rear pair of casters are lockable for stabilizing whirlpool during treatment.

Turbine Raising and Lowering Device permits adjustment of desired height and direction of water agitation towards the area of the body to be treated. It is spring balanced and provided with a locking device.

Turbine Assembly functions both as agitator and emptying device. It is equipped with Underwriters Laboratory listed 1/2 HP jet pump motor protected with an ABS plastic shell, and automatic thermal overload protector, and lifetime-sealed bearings. All parts contacting the water are stainless steel, chrome plated brass or bronze.

Thermometer is provided with a dual scale, adjustable calibration, and a stem inserts into a retainer to prevent rattle during whirlpool agitation.

GUIDE SPECIFICATIONS

Provide Mobile Whirlpool (specify model number and options) with a 105-gallon capacity, 66"L x 24"W x 18"D. Whirlpool shall be fabricated from heavy gauge, type 304 stainless steel. Construction shall be seamless welded and exposed surfaces shall be polished to satin finish. Tank shall have a reinforced rim and shall be fitted with an auxiliary drain valve. Bottom of tank shall be a seamless, rounded covered design to minimize bacteria build up. Whirlpool shall have heavy duty swivel casters with locking device on rear pair of casters. Provide a turbine assembly with raising and lowering device which functions both as agitator and emptying device, permits adjustment of desired height, direction of water agitation, and can be locked into place. Turbine assembly shall be UL listed 1/2 HP jet pump motor with automatic thermal overload protector, and lifetime-sealed bearings. Provide a thermometer with a stem retainer to prevent rattle when whirlpool is in operation.



Member of
U.S. Green
Building
Council



Recyclable
Product

Lo-Boy Whirlpools

Series

- L Lo-Boy Series

Capacity

- 105 Gallons

Type

- M Mobile Whirlpool

Suffix Options (see Whirlpool Option Section for Details)

- ADH Auxiliary Drain Hose Assembly
- ALC Adjustable Low Chair
- ALS Adjustable Low Stool
- ARS Arm Rest Support
- AS3 Adjustable Suspension Seat
- CTS3 Combination Table with Side Seats
- EG Enviro Glaze Color Powder Coating

Specify Color: _____
(Special Finish Consult Factory)

MODEL NUMBER AND OPTION SELECTIONS

- GFI Ground Fault Interrupter
- HR Head Rest, Adjustable
- PCS Pump Cover Strainer
- PHS2 Patient Handling System (Chair Type)
- RHG Rubber Hand Grips
- RS Reclining Seat
- TTS2 Tank Top Seat

Note: Separate Drain and Overflow Assembly (-SDO) is not available with Model L-105-M.

Turbine rated at 115V, 60Hz; if 220V is required please specify: 50Hz 60Hz

ELECTRIC REQUIREMENTS:
Amps: 8
Volts: 115
Hertz: 60
GFI Receptacle



L-105-M
Standard
Mobile
Whirlpool

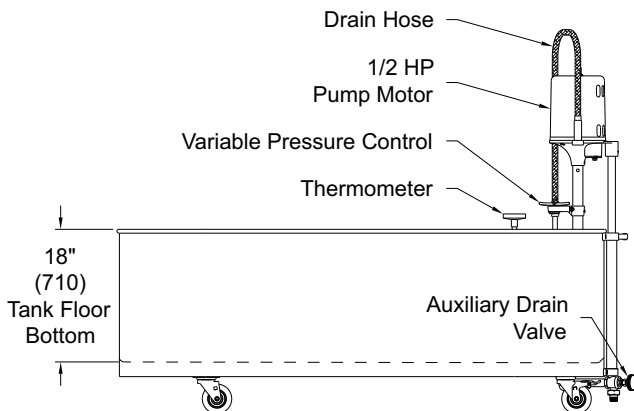
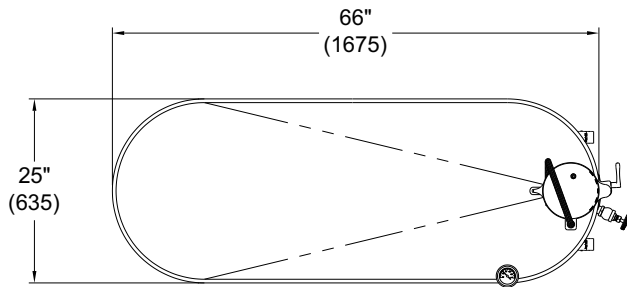

L-105-M-SDP
Mobile Whirlpool
With Separate
Drain Pump

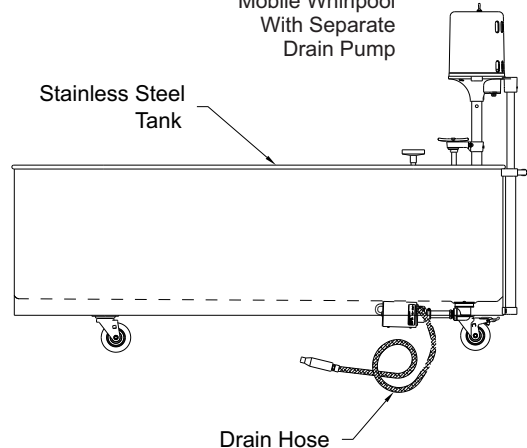

L-105-M-DS
Mobile Whirlpool
With Sump

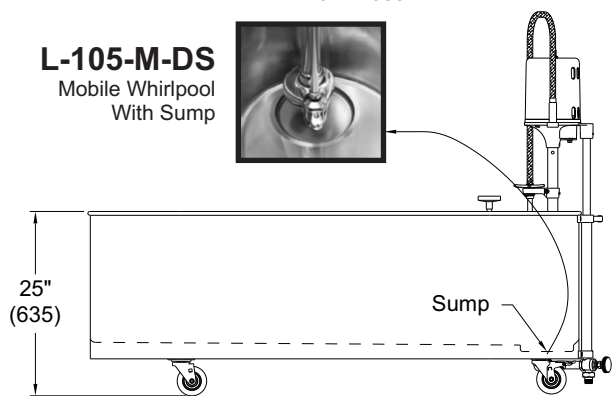

SELECTION SUMMARY & APPROVAL FOR MANUFACTURING

Model Number & Options _____ Quantity _____
Company _____ Date _____
Contact _____ Title _____
Approval for Manufacturing/Signature _____