

# ASSIST™ A8AS100

STANDARD HEIGHT PREMIUM TOILET SEAT  
+ SUPPORT ARMS

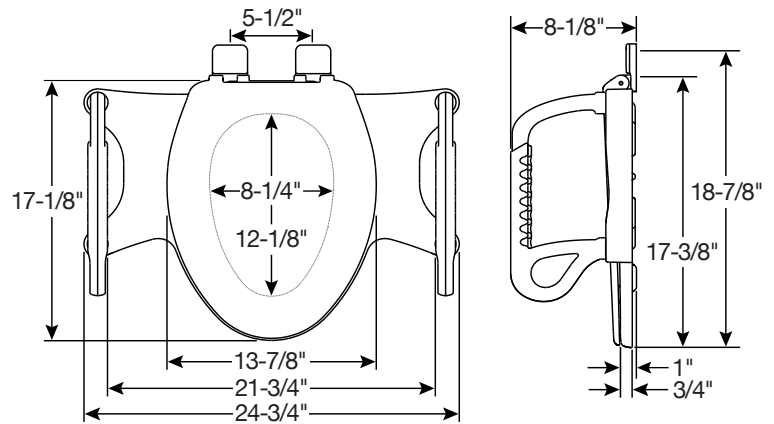

## FEATURES:

- **Support Arms**  
Assists in sitting and standing
- **Stay-Tite® Commercial Fastening System™**  
Never loosens. Guaranteed.
- **Universal Fit**  
Fits both round & elongated toilets
- **Residential Appearance**  
Blends with home interiors
- **Larger Seat Opening**  
Better hygiene and comfort
- **Seat Lifts**  
For standing use and cleaning
- **Easy-to-Clean**  
Smooth, glossy surface

## SPECIFICATIONS:

**Size:** Round / Elongated

**Material:** Plastic

**Style:** Closed Front with Cover

**Ring Bumpers:** 12 Molded Stabilizing Ribs

**Hinges:** Non-Corroding 300 Series Stainless Steel Pintles

**Hardware:** Stay-Tite® Commercial Fastening System™

**Seat Capacity:** 500 lbs \* | 21-3/4" between bars

**Support Arm Capacity:** 250 lbs each

**Codes & Standards:**  Complies with IAPMO/ANSI Z124.5 Performance Standards Heavy-Duty Commercial

\* Always check the load-bearing weight of the water closet.

