



This manual has been prepared for the owners and operators of the ARMEDICA™ AM-Series Mat Tables. It contains installation instructions, precautionary instructions and maintenance procedures for the following model numbers:

AM-640, AM-641, AM-642, AM-643, AM-644,
AM-645, AM-650, AM-652 AM-654,
AM-660, AM-662, AM-664



ISO 13485
FM 50089

Made in the U.S.A

Armedica Treatment Tables are intended to be used as physical therapy supports for patients during clinician attended physical therapy related diagnosis, treatment, and monitoring. The table is equipped with vertical table height adjustment actuators. Patients are not to be left unattended.

INSTALLATION INSTRUCTIONS FOR ARMEDICA™ MAT PLATFORM TABLES

1. Remove the mat platform from the carton, leaving the foam covering on the upholstered top.
2. Place the platform top with the bottom side up on a clean, smooth surface and remove the wood packing frame and strapping from the motor on electric models. On adjustable models with a manual crank, remove strapping and install the unit referring to the picture of model AM-642 (pg 4).
3. Remove the screws (A) holding the legs to the underside of the table and carefully un-wrap.

CAUTION:

ON ELECTRIC AND ADJUSTABLE MODELS

DO NOT FOLD OR KINK HYDRAULIC LINES AT ANY TIME

4. Gently rotate legs into position as shown and insert bolts (3) with the bolt head and finishing cap washers (27) on the outside of the table frame. Tighten bolts securely using the nuts (13) provided. Attach the black finishing caps (28) to bolt heads by pressing firmly. Extra cable clamps and screws are included for additional cable clamping if necessary.
5. Install leveling glides by screwing them into the legs.
6. Place the mat platform upright and remove the foam covering. Adjust the leveling glides as needed. The mat platform is ready for use. For powered models plug the power cord into a properly grounded 120 volt AC outlet. Power cord is hospital grade and reliability of unit can only be achieved when connected to an equivalent receptacle.

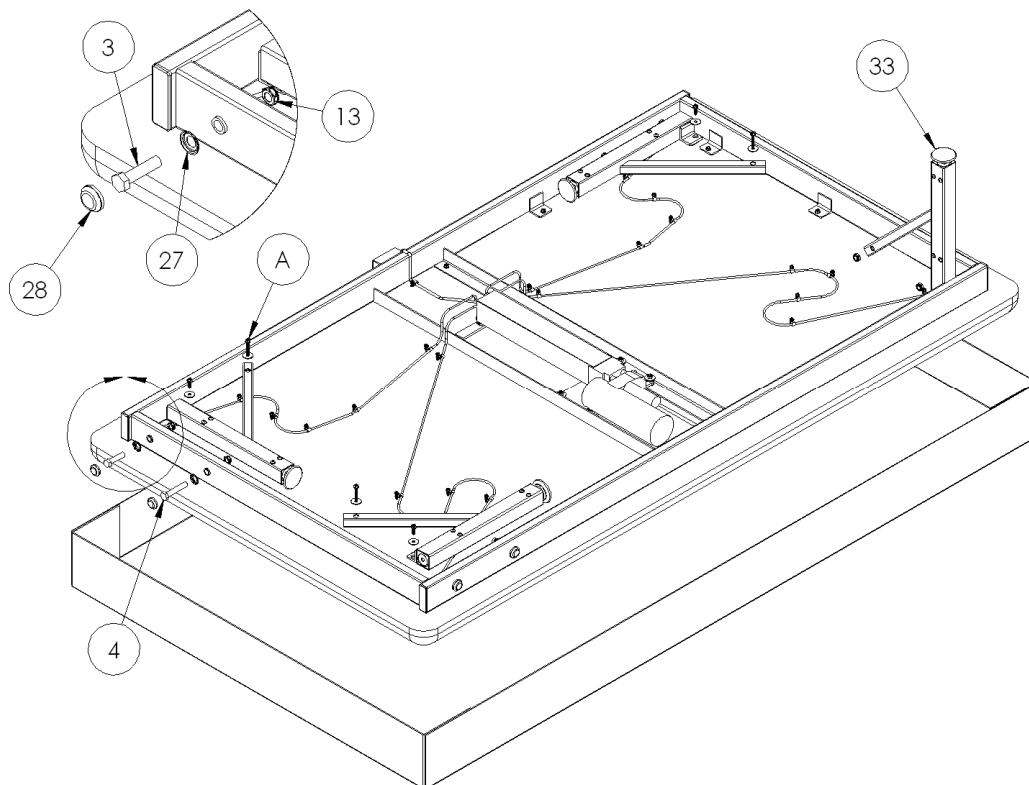

OPERATING INSTRUCTIONS

To adjust the height of the Armedica™ Power Mat Platform, a low voltage toggle switch or optional foot switch is used to activate the motorized hydraulic pump. The up (UP) or down (DN) motion is clearly indicated on the foot switch.

The motors are equipped with a thermal cutoff that protects them from overheating.

Duty cycle on/off int. 1 min. / 5 min.

The Armedica™ Adjustable Mat Platform is adjusted with a crank handle that activates the hydraulic pump. Turning the handle clockwise will raise the table. Counter clockwise will lower it.

The handle will automatically lock into place when extended for use. Make certain the handle is fully engaged prior to turning. To release and lower the handle once the desired height is reached, firmly pull the handle out until it is able to be lowered.

The moveable section on the adjustable back model is activated by grasping the handle located at the center of the back section. Release to lock at desired position.

This equipment has been tested and found to comply with the limits for medical devices to the IEC 60601-1-2: Third edition 2007-03. These limits are designed to provide reasonable protection against harmful interference in a typical medical installation. This equipment generates, uses and can radiate radio frequency energy and, if not installed and used in accordance with the instructions, may cause harmful interference to other devices in the vicinity. However, there is no guarantee that interference will not occur in a particular installation. If this equipment does cause harmful interference to other devices, which can be determined by turning the equipment off and on, the user is encouraged to try to correct the interference by one or more of the following measures:

- Reorient or relocate the receiving device.
- Increase the separation between the equipment.
- Connect the equipment into an outlet on a circuit different from that to which the other device(s) are connected.
- Consult the manufacturer or field service technician for assistance.

MAINTENANCE

The Armedica™ Electric Power Mat Platforms and Adjustable Mat Platforms are equipped with a maintenance free hydraulic system.

On all mat platforms frequently check to make certain that all hardware (nuts, bolts, etc.) are securely fastened.

The vinyl cover can be cleaned with mild soap and water and the frame wiped with a dry cloth.

SYMBOLS AND INDICATORS



Attention: Consult accompanying documents.



Type B Equipment: "An adequate degree of protection against electric shock is provided, particularly regarding leakage currents and reliability of the protective earth connection."

TROUBLE SHOOTING

TABLE WILL NOT OPERATE

- A. Check to see if the power cord is properly plugged into the electrical outlet.
- B. Make sure the hand switch or foot switch is securely plugged in.
- C. Thermal cutoff may have activated. Allow motor to cool.

MOTOR SPECIFICATIONS

Bucher Hydraulics, Inc Model 4E-D2A-10-XX028
1363 Michigan St. N.E. 115 VAC 2.4 Amps
Grand Rapids, MI 49503 Short Duty on/off 1 min. / 5 min.

Transport and Storage

Ambient Temperature: -34 to 65 deg. C
Relative Humidity: 15 to 95%, including condensation
Atmospheric Pressure: 500hPa to 1030hPa

Table lift capacity 900 lbs.

PARTS LIST

ITEM	PART #	DESCRIPTION	QTY FOR POWER			QTY FOR MANUAL			QTY FOR FIXED			QTY FOR 4x7 AJD BACK		
			4x7	5x7	6x8	4x7	5x7	6x8	4x7	5x7	6x8	POWER	MANUAL	FIXED
1	02004	SPRING GAS HY3 VARILOCK										1	1	1
2	02036	SCREW BTN HD SOC 1/4-20x3/8	16	16	16	16	16	16				16	16	
3	02046	SCREW HX HD CAP 1/2-13x2	4	4	4	4	4	4	4	4	4	4	4	4
4	02047	SCREW HX HD CAP 1/2-13x2-3/4	4	4	4	4	4	4	4	4	4	4	4	4
5	02050	SCREW HX HD CAP 5/16-18x1-3/4										1	1	1
6	02054	SCREW HX HD CAP 1/4-20x1-3/4										4	4	4
7	02063	SCREW HX WASHER HD #10x3/4	24	24	24	24	24	24				24	24	
8	02065	SCREW HX WASHER HD #14x1	18	20	20	12	20	20	18	14	22	18	18	18
9	02069	SCREW HX HD CAP 1/4-20x3				3	3	3					3	
10	02070	SCREW HX WASHER HD #14x1-3/4										6	6	6
11	02088	SCREW FLT HD SOC 10-32x1/2										2	2	2
12	02089	NUT NYLOCK 10-32										2	2	2
13	02095	NUT NYLOCK JAM 1/2-13	8	8	8	8	8	8	8	8	8	8	8	8
14	02100	NUT NYLOCK 1/4-20	5	5	5	4	4	6				4	4	4
15	02104	WASHER 1/4" INTERNAL TOOTH LOCK	16	16	16	16	16	16				16	16	
16	02105	NUT NYLOCK 5/16-18										4	4	4
17	02143	WASHER FENDER 1/4"IDx1"OD	13	13	13	8	8	8	8	8	8	13	13	8
18	02150	WASHER 5/16	4									4	4	4
19	02173	SCREW HX HD 5/16-18x3-1/4										2	2	2
20	02181	SCREW HX HD CAP 5/16-18x2-1/2										1	1	1
21	02200	CLAMP CABLE 3/16 BLACK	24	24	24	24	24	24				24	24	
22	02201	CLAMP CABLE 1/4 WHITE	5	5	5							5		
23	02204	CABLE TIE ADHESIVE MOUNT										4	4	
24	02235	CABLE TIE 1/16" X 6"										8	8	
25	02236	CABLE TIE 1/16" X 8"										4		
26	03010	PLUG 1x1x14GA										3	3	3
27	03011	WASHER RHW-207 FINISH CAP	8	8	8	8	8	8	8	8	8	8	8	8
28	03012	CAP FINISH BLACK BOLT COVER	8	8	8	8	8	8	8	8	8	8	8	8
29	03015	PLUG 1x2x14GA										2	2	2
30	03016	PLUG 1x3x14GA	4	4	4	4	4	4	4	4	4	4	4	4
31	03018	PLUG 1-3/4SQ-14-20 BLACK							3	3	3			3
32	03038	SWITCH CONTROL MNTD PWR MAT												
33	03061	GLIDE 2-1/2 BASEx1/2-13x2-1/2							1	1	1			1
34	03065	GLIDE 1/4-20x1										4	4	4
35	03080	RIV NUT 1/4-20 14GA										4	4	4
36	03129	RIBBED BUSHING 9311K143	5	5	5							5	5	
37	03138	BUSH INSULATING.375 IDx.500 OD BLK										2	2	
38	03139	FLAT RIBBED BUSHING 9311K145	5	5	5							5	5	
39	03231	CABLE CMA REMOTE SYSTEM										1	1	1
40	03400	DYNA-LIFT MOTOR ELEC	1	1	1							1		
41	03401	DYNA-LIFT CRANK ASSY MANUAL MAT				1	1	1					1	
42	03408	SWITCH FOOT POWER MAT												
43	12425	BAR 1/8x1x4-9/16 CRANK SPPT PLTD				1	1	1					1	
44	12803	BAR 1/8X2-1/2X4 HYD ADPTR PLTD						1						
45	14404	BD UPH 6x8 STEEL MAT TABLE			1			1			1			
46	14409	BD UPH 4x7 PWR MAT	1			1			1					
47	14410	BD UPH STEEL MAT 5x7		1			1			1				
48	14413	BD UPH 29x48 MAT 4x7 2PC HD SEC										1	1	1
49	14414	BD UPH 48x57 MAT 4x7 2PC BODY										1	1	1
50	18401	LEG PWR MAT PAINTED	4	4	4	4	4	4				4	4	
51	18403	FRAME TOP PWR MAT 4x7 ELEC PAINTED	1			1			1					
52	18409	FRAME TOP POWER MAT 5x7 PAINTED		1			1			1				
53	18417	FRAME TOP PWR MAT 6x8 PAINTED			1			1			1			
54	18421	LEG CONTEMP MAT PAINTED							3	3	3			3
55	18423	LEG W/GLIDE LEVEL CONTEMP MAT PNTD							1	1	1			1
56	18436	BAR 1/8x1x9-1/4 ADJ MAT ADAPT PLTD				1	1						1	
57	18442	BRKT ADAPTER 6x8 ADJ MAT PLTD						1						
58	18457	FRM BACK MAT 4x7 ADJ BK PNTD										1	1	1
59	18463	TUBE 1X2X3 CBL RELEASE LEVER PNTD										1	1	1
60	18467	FRAME TOP 4x7 W/BACK SEC PNTD										1	1	1

MAT PLATFORM
AM-644, AM-654, AM-664

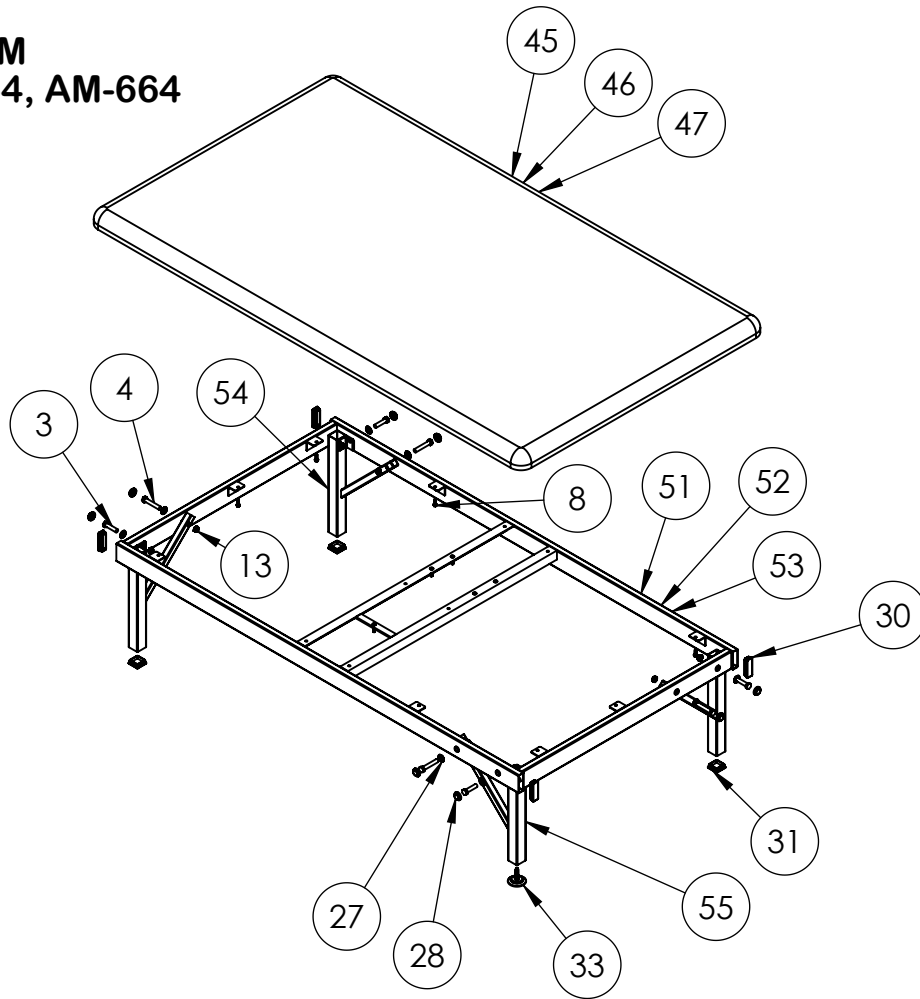

MAT PLATFORM
AM-642, AM-652, AM-662

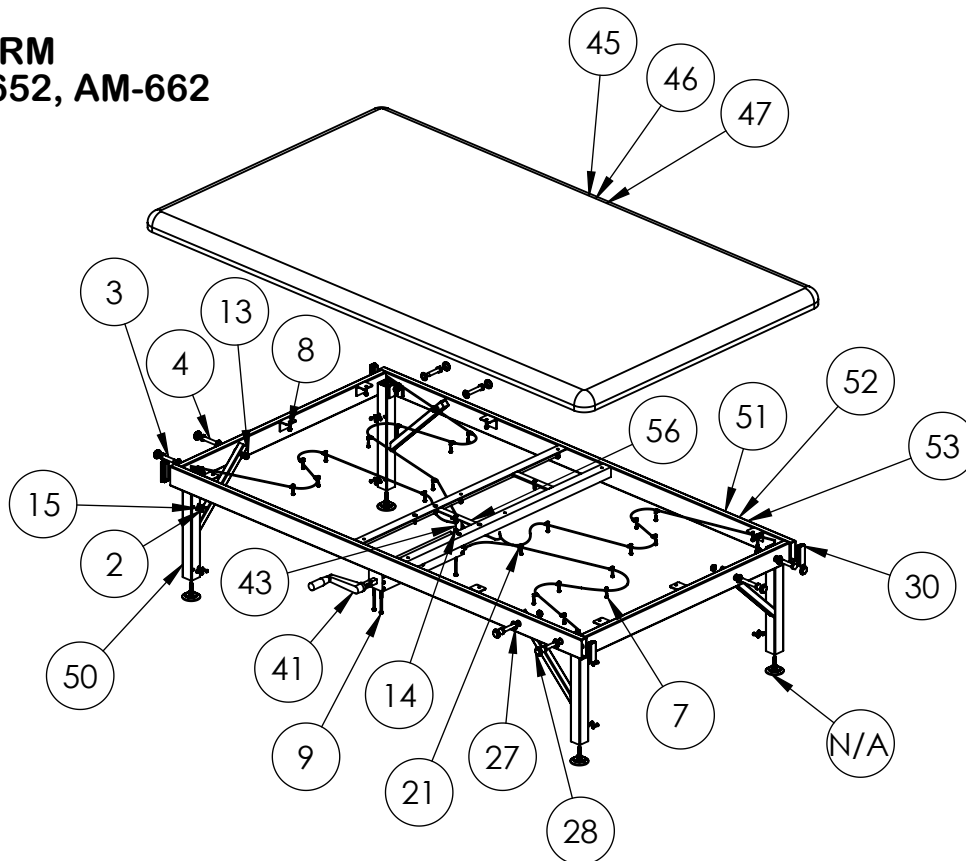

MAT PLATFORM
AM-640, AM-650, AM-660

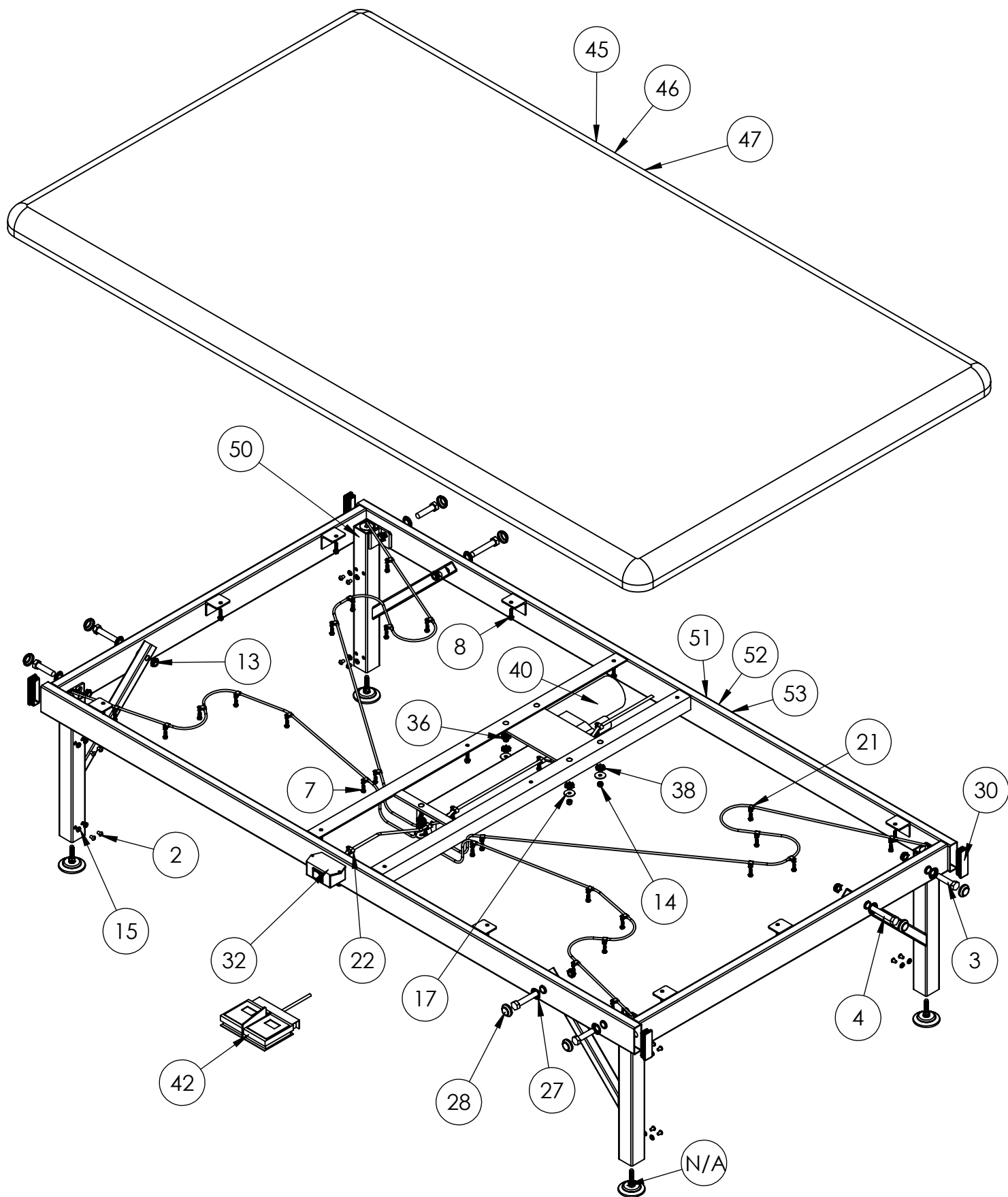

MAT PLATFORM
AM-641, AM-643, AM-645

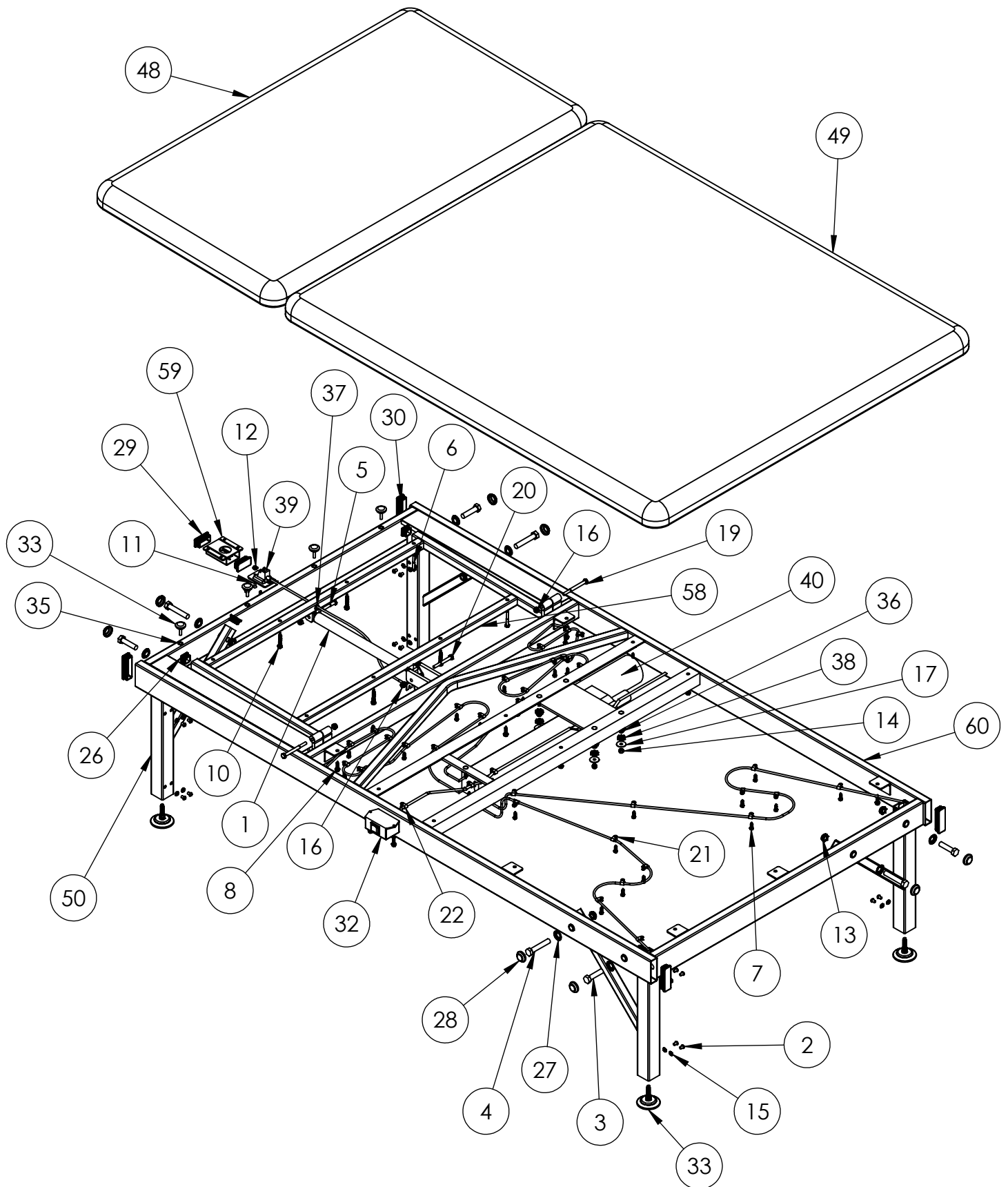

ARMEDICATM MANUFACTURING CORP. LIMITED WARRANTY

ARMEDICATM Manufacturing Corp. warrants that the AM-Series Mat Platforms are free from defects in material and workmanship. This warranty shall remain in effect for 18 months from the date of original consumer purchase of the product. The Hydraulic units on the Power Mat Platforms and Adjustable Mat Platforms are warranted to be free from defects in materials and workmanship for 18 months from the date of original consumer purchase of the product. The welded steel frames on all Mat Platforms are warranted to be free from defects in materials or workmanship for 5 years from the date of original consumer purchase of the product. If the table fails to function during the warranty period due to a defect in material or workmanship, ARMEDICATM Manufacturing Corp. or the selling Dealer will repair or replace the table without charge within a 30 day period from the date on which the table is returned to ARMEDICATM Manufacturing Corp. or the selling Dealer.

THIS WARRANTY DOES NOT COVER

1. Replacement parts or labor furnished by anyone other than ARMEDICATM, Selling Dealer or any approved ARMEDICA Service Agent. Parts lists are for reference only when speaking with an ARMEDICA representative. Replacements and repairs are to be done by an approved ARMEDICA Service Agent.
2. Any failure of the table during the warranty period if the failure is not caused by a defect in material or workmanship or if the failure is caused by unreasonable use, including the failure to provide reasonable and necessary maintenance.

ARMEDICATM MANUFACTURING CORP. IS NOT LIABLE FOR INCIDENTAL OR CONSEQUENTIAL DAMAGE TO PROPERTY OR BUSINESS.

TO OBTAIN SERVICE from ARMEDICATM or the Selling Dealer under this warranty, please do the following:

1. A written claim should be sent to ARMEDICATM Manufacturing Corp., P.O. Box 880, Greenwood, AR. 72936-0880 or the selling Dealer.
2. The table must be returned to ARMEDICATM Manufacturing Corp. or the selling Dealer.
3. This warranty gives you specific legal rights and you may have other rights which vary from state to state.

ARMEDICATM does not authorize any person or dealer to create for it any other obligations or liabilities in connection with the sale of the tables. Any representation or agreement not contained in this warranty shall be void. Disposal of unused or unwanted product should be in accordance with applicable regional, national, and local laws. For information contact the local regulatory agency.

ARMEDICA MANUFACTURING CORP. Greenwood, AR 72936-0880 Mat Platform	
Model No. <input type="text"/>	Serial No. <input type="text"/>
Capacity 900 lb. (410 kg.)	
DANGER: Risk of explosion if used in the presence of flammable anesthetics. Duty cycle: On/Off Int. 1 min./5 min. Medical Electrical Equipment with respect to electrical shock. Fire and mechanical hazards only in Accordance with 60601-1. 120VAC @ 60 Hz/2.4 Amps	
 ETL CLASSIFIED C US Intertek 4029555	 D60308